

**MODEL**

- RA2 - Steel round diffuser, 4 cones, fully adjustable

**FEATURES**

- Horizontal/Vertical air distribution; units ship in vertical position
- Designed for heating and cooling applications
- 360° discharge air pattern
- Excellent performance in variable air volume systems
- Designed for exposed duct or hard ceiling applications

**INLET SIZES**

- Round: 6" - 20" (2" increments), 24", 30", 36" <sup>1</sup>

**COMPATIBLE OPTIONS AND ACCESSORIES**

- Safety chain (optional on sizes under 12", standard on 12" and larger)
- PR10 - Steel, radial opposed blade damper, 12" max (neck mount)
- PRN100 - Steel, radial fan damper, 14" max (neck mount)
- PRD10 - Steel, radial opposed blade damper (duct mount)
- PRD100 - Steel, radial fan damper, 14" max (duct mount)
- PR12 - Steel, butterfly bladed damper, 24" max (duct mount)
- RSG15 - Steel, round straightening grid (duct mount)
- PRSG15 - Steel, round straightening grid
- OBDDM - Steel, square or rectangular damper (duct mount)
- EX8 - Steel duct extractor with 1" blade spacing (duct mount)
- EX88 - Steel duct extractor with 2" blade spacing (duct mount)

NOTES: Not all options available with all configurations or one another. Some options must be ordered separately. See website for complete compatibility.

<sup>1</sup> Safety chain included on all units with 12" or greater inlet size.

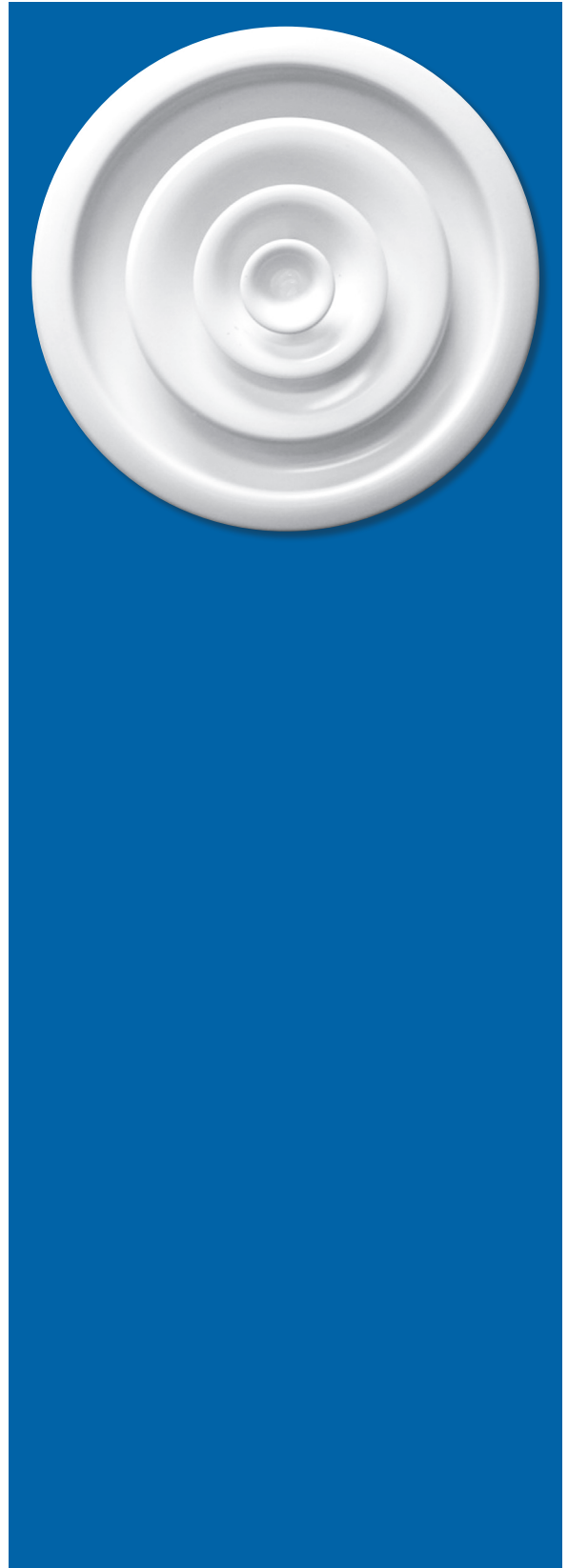

# RA2

Round Diffuser, 4 Cones, Fully Adjustable



## DIMENSIONAL DATA

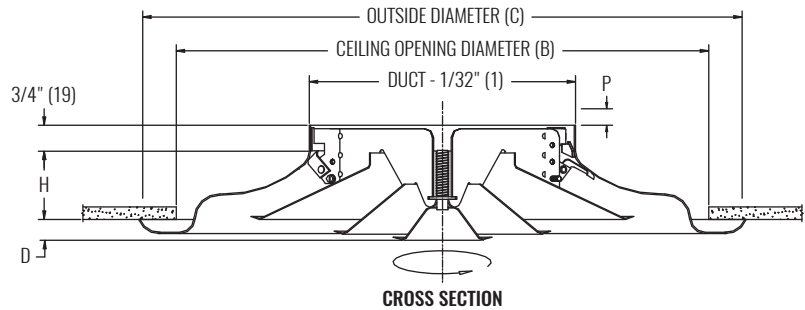

NOTES: Dimensions in parentheses are millimeters (mm). Adjusting shaft projects above the neck of the diffuser on sizes 14 through 36. The maximum amount of this projection is Dimension P.

DIMENSIONS						
NOMINAL ROUND DUCT	CEILING OPENING DIAMETER B	OUTSIDE DIAMETER C	POSITION 1 (HORIZONTAL) D	POSITION 3 (VERTICAL) D	H	P
6"	12" (305)	13 1/2" (343)	1 7/16" (37)	11/16" (17)	1 5/8" (41)	-
8"	16" (406)	18" (457)	1 13/16" (46)	7/8" (19)	2 1/8" (54)	-
10"	20" (508)	22 1/2" (572)	2 1/4" (57)	1 1/8" (29)	2 5/8" (67)	-
12"	24" (635)	27" (686)	2 11/16" (68)	1 1/4" (32)	3 1/4" (83)	-
14"	28" (711)	31 1/2" (800)	3 1/8" (79)	1 3/16" (30)	3 3/4" (95)	2 1/2" (64)
16"	32" (813)	36" (914)	3 5/16" (84)	1 5/16" (33)	4 1/4" (108)	2 5/8" (67)
18"	36" (914)	40 1/2" (1029)	3 3/4" (95)	1 1/2" (38)	4 7/8" (124)	2 3/4" (70)
20"	40" (1016)	45" (1143)	4 1/8" (105)	1 5/8" (41)	5 3/8" (137)	3" (76)
24"	48" (1219)	54" (1372)	4 7/8" (121)	1 7/8" (48)	6 1/2" (165)	3 1/8" (79)
30"	60" (1524)	67 1/2" (1715)	5 9/16" (141)	1 7/8" (48)	8" (203)	4 3/8" (111)
36"	60" (1524)	67 1/2" (1715)	5 9/16" (141)	1 7/8" (48)	8" (203)	4 3/8" (111)

## PERFORMANCE AND DESIGN DATA

SIZE		PERFORMANCE				DESIGN - BASED ON HORIZONTAL THROW		
NOMINAL INLET	POSITION	NC (< 25)		NC (25 - 40)		CFM @ NC-30	SPACING @ 0.6 CFM/sf (ft)	MINIMUM CFM/sf
		CFM	THROW (ft)	CFM	THROW (ft)			
HZ = HORIZONTAL DISCHARGE AIR PATTERN / VT = VERTICAL DISCHARGE AIR PATTERN								
8"	HZ	70 - 230	3 - 9	250 - 384	10 - 12	280	22	0.35
8"	VT	70 - 224	1 - 8	240 - 384	9 - 16	260	N/A	N/A
10"	HZ	109 - 355	4 - 11	375 - 600	12 - 15	430	27	0.35
10"	VT	109 - 339	1 - 9	363 - 545	10 - 18	400	N/A	N/A
12"	HZ	157 - 490	4 - 13	520 - 800	14 - 17	620	32	0.35
12"	VT	157 - 471	1 - 9	510 - 785	11 - 21	590	N/A	N/A
14"	HZ	214 - 665	5 - 16	690 - 1069	16 - 20	825	37	0.35
14"	VT	214 - 641	1 - 11	689 - 1069	13 - 25	800	N/A	N/A
16"	HZ	279 - 838	6 - 18	900 - 1396	18 - 23	1000	41	0.35
16"	VT	279 - 815	1 - 11	838 - 1396	12 - 28	980	N/A	N/A
18"	HZ	353 - 1060	7 - 20	1120 - 1767	20 - 26	1350	47	0.35
18"	VT	353 - 1031	1 - 12	1060 - 1679	13 - 30	1300	N/A	N/A

NOTES: Information shown is abbreviated. See website for complete information. Dimensions in parentheses are millimeters (mm). Throw value ranges are given for isothermal conditions, unless otherwise noted, and a terminal velocity of 50 FPM (0.25 m/s). NC ranges are based on octave band 2 - 7 sound power levels minus a room absorption of 10dB, re 10<sup>-12</sup> Watts. Data was obtained from tests conducted in accordance with ANSI/ASHRAE Standard 70, ISO Standard 5219, and ISO Standard 3741. Design spacing is recommended distance between diffusers in an open plan office based on ADPI > 80%, 9ft ceiling, and 55°F discharge at 30 NC and 0.6 CFM/sf. Minimum CFM/sf is based on recommended spacing at 80% ADPI. Design recommendations not applicable to vertical throw. "N/A" in design table denotes inapplicable situations or those which do not result in ADPI>80% and are therefore not recommended.

© Copyright Krueger 2018