

MODEL

- 5810 - Fixed blade, removable, reversible core, aluminum return

FEATURES

- Field adjustable 5° or 15°, up or down deflection
- Horizontal (H) or vertical (V) front blades
- Available as core only

GRILLE SIZES

- Width: 6" - 48" (1/4" increments)
- Height: 4" - 48" (1/4" increments)
- Core Only Width: 6" - 72" (1/4" increments)
- Core Only Height: 4" - 24" (1/4" increments)

FRAME STYLES

- F00 - Core only ¹
- F22 - Surface mount

COMPATIBLE OPTIONS AND ACCESSORIES

- Flat frame
- Screw holes
- OBD - Steel, square or rectangular damper
- 5OBD - Aluminum, square or rectangular damper
- POBD - Steel, square or rectangular painted damper
- SRAC325 - Steel, square to round adapter
- DS - Debris screen (1/4" mesh) or IS - Insect screen (1/16" mesh)

NOTES: Not all options available with all configurations. Many options not compatible with other options. Size limitations on accessories. See website for complete compatibility.

¹ F00 (core only) not available with screw holes, frame, dampers, or debris/insect screens.

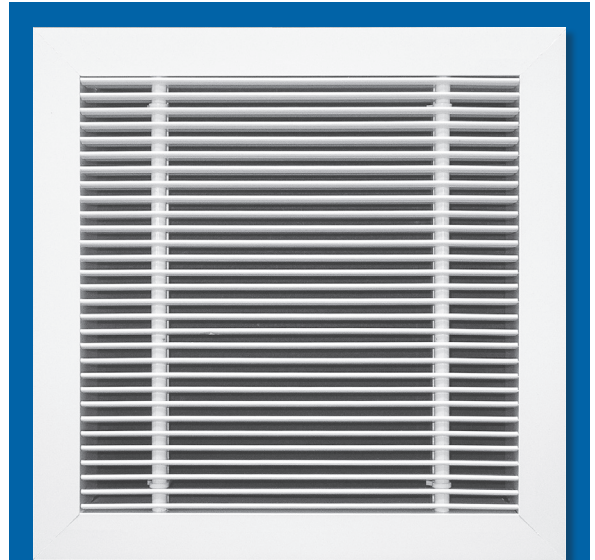

DIMENSIONAL DATA

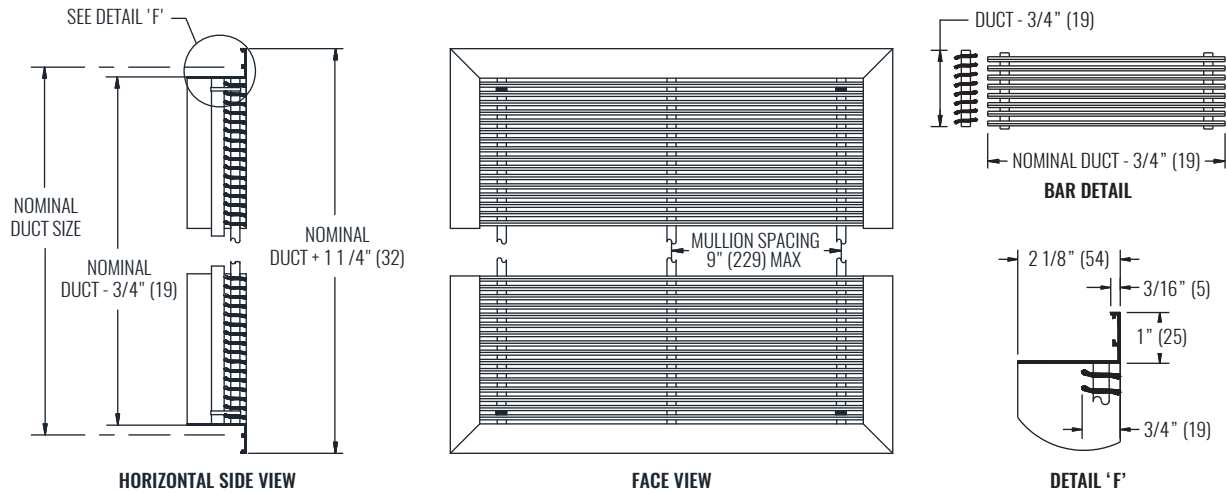

NOTES: Dimensions in parentheses are millimeters (mm).

PERFORMANCE DATA

SIZE	PERFORMANCE	
	NC (< 25)	NC (25 - 40)
NOMINAL	CFM	CFM
6"x6"	50 - 150	175 - 250
8"x6"	50 - 200	238 - 350
8"x8"	75 - 263	309 - 450
10"x4"	50 - 163	191 - 275
10"x10"	125 - 400	469 - 675
12"x8"	125 - 388	453 - 650
12"x12"	150 - 550	650 - 950
14"x14"	200 - 725	856 - 1250
16"x16"	250 - 925	1094 - 1600
22"x22"	500 - 1650	1938 - 2800
22.5"x22.5"	500 - 1700	2000 - 2900
36"x24"	700 - 2650	3138 - 4600

SEE BACK SUPPLEMENT FOR DESIGN INFORMATION

NOTES: Information shown is abbreviated. See website for complete information. Dimensions in parentheses are millimeters (mm). NC ranges are based on octave band 2 - 7 sound power levels minus a room absorption of 10dB, re 10⁻¹² Watts. Data was obtained from tests conducted in accordance with ANSI/ASHRAE Standard 70, ISO Standard 5219, and ISO Standard 3741.