

### MODEL

- 5DMGSR - Single deflection spiral duct supply grille with end caps, curved to fit a specific duct diameter

### FEATURES

- All aluminum construction
- Horizontal (H) or vertical (V) blades
- 3/4" blade spacing

### GRILLE SIZE

- Width: 10" - 48" (1" increments)
- Height      Min Width      Duct Diameter
 

Height	Min Width	Duct Diameter
3"	10"	6" - 36"
4"	10"	6" - 36"
6"	10"	8" - 36"
8"	10"	10" - 36"
10"	10"	12" - 36"
12"	12"	14" - 36"
- Duct diameter available in 2" increments

### COMPATIBLE OPTIONS AND ACCESSORIES

- Damper/Extractor <sup>1</sup>

#### NOTES:

<sup>1</sup> Damper/Extractor must be ordered with the product; cannot be retrofitted.

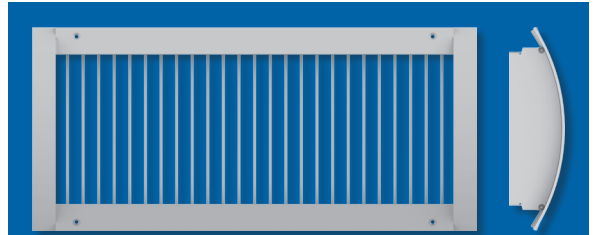

FACE AND SIDE VIEW (VERTICAL)



FACE AND SIDE VIEW (HORIZONTAL)

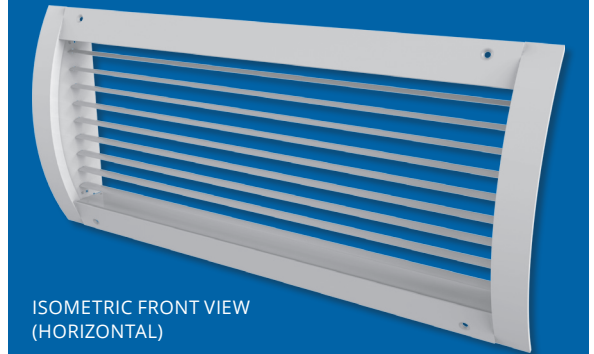

ISOMETRIC FRONT VIEW (HORIZONTAL)



# 5DMGSR

Spiral Duct Grille, Single Deflection, Radius Endcap



## DIMENSIONAL DATA

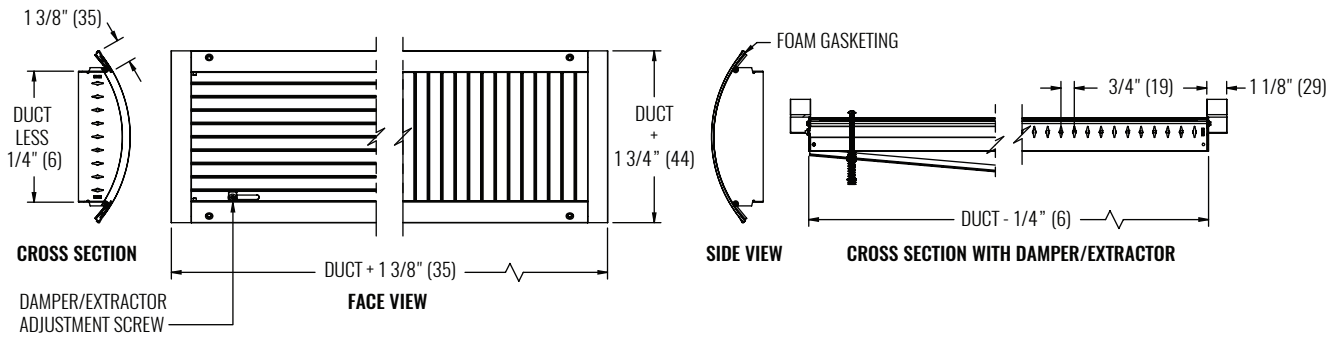

### AVAILABLE SIZES AND MINIMUM DUCT DIAMETER

DESCRIPTION	HEIGHT					
	3" (76)	4" (102)	6" (152)	8" (203)	10" (254)	12" (305)
WIDTH MIN / MAX	10" (254) / 48" (1219)	10" (254) / 48" (1219)	10" (254) / 48" (1219)	10" (254) / 48" (1219)	10" (254) / 48" (1219)	12" (305) / 48" (1219)
DUCT DIAMETER MIN / MAX	6" (152) / 36" (914)	6" (152) / 36" (914)	8" (203) / 36" (914)	10" (254) / 36" (914)	12" (305) / 36" (914)	14" (356) / 36" (914)

NOTES: Dimensions in parentheses are millimeters (mm).

## PERFORMANCE DATA

SIZE	PERFORMANCE - FREE JET THROW								
	W x H	CFM	NC (< 25)			CFM	NC (25 - 40)		
			DEFLECTION	DEFLECTION	DEFLECTION		DEFLECTION	DEFLECTION	DEFLECTION
0° THROW (ft)	22.5° THROW (ft)	45° THROW (ft)	0° THROW (ft)	22.5° THROW (ft)	45° THROW (ft)				
18"x3"	63 - 176	10 - 17	8 - 13	4 - 8	183 - 290	18 - 22	14 - 17	8 - 10	
10"x4"	63 - 141	10 - 15	8 - 12	5 - 7	147 - 233	16 - 20	12 - 15	7 - 19	
12"x4"	51 - 167	8 - 17	6 - 13	4 - 8	173 - 276	17 - 22	13 - 17	8 - 10	
10"x6"	72 - 213	10 - 19	8 - 15	4 - 9	221 - 352	19 - 24	15 - 19	9 - 11	
12"x6"	90 - 252	11 - 21	9 - 16	5 - 9	262 - 417	21 - 27	16 - 21	9 - 12	
14"x6"	97 - 290	11 - 22	9 - 17	5 - 10	300 - 480	23 - 28	17 - 22	10 - 13	
16"x6"	117 - 328	13 - 24	10 - 18	6 - 11	340 - 542	24 - 30	19 - 23	11 - 14	
18"x6"	125 - 365	13 - 25	10 - 19	6 - 11	377 - 603	25 - 32	20 - 35	11 - 14	
12"x8"	108 - 333	12 - 24	9 - 18	5 - 11	346 - 551	12 - 31	10 - 24	6 - 14	
14"x8"	133 - 384	13 - 25	10 - 20	6 - 11	398 - 634	36 - 33	20 - 25	12 - 15	
18"x8"	159 - 481	14 - 29	11 - 22	6 - 13	499 - 796	29 - 37	23 - 28	13 - 17	
20"x8"	194 - 529	16 - 30	12 - 23	7 - 13	548 - 875	30 - 38	24 - 30	14 - 17	

### SEE BACK SUPPLEMENT FOR DESIGN INFO

Information shown is abbreviated. See website for complete information. Dimensions in parentheses are millimeters (mm). Throw value ranges are given for isothermal conditions, unless otherwise noted, and a terminal velocity of 50 FPM (0.25 m/s). NC ranges are based on octave band 2 - 7 sound power levels minus a room absorption of 10dB, re 10<sup>-12</sup> Watts. Data was obtained from tests conducted in accordance with ANSI/ASHRAE Standard 70, ISO Standard 5219, and ISO Standard 3741.