

MODEL

- 9180 - Stainless steel, curved blade supply grille

FEATURES

- 304 stainless steel construction (316 optional)
- 1, 2, 3, and 4-way deflection
- Adjustable blades
- Excellent choice for residential and commercial buildings where different throw characteristics are needed for the same sized grille

GRILLE SIZE

- Width: 4" - 48" (1" increments)
- Height: 4" - 48" (1" increments)

FRAME STYLES

- F22 - Surface mount
- F23 - Lay-in T-bar

PANEL SIZES

- 24"x24"
- 48"x24"

COMPATIBLE OPTIONS AND ACCESSORIES

- Countersunk screw holes ¹
- 9OBD - Stainless steel OBD welded to unit, face adjustable
- 98PF - Stainless steel plaster frame
- 9SRA - Stainless steel square to round adapter

NOTES:

- ¹ Unit shipped with #6x1 1/4" stainless steel sheet metal screws.



DIMENSIONAL DATA

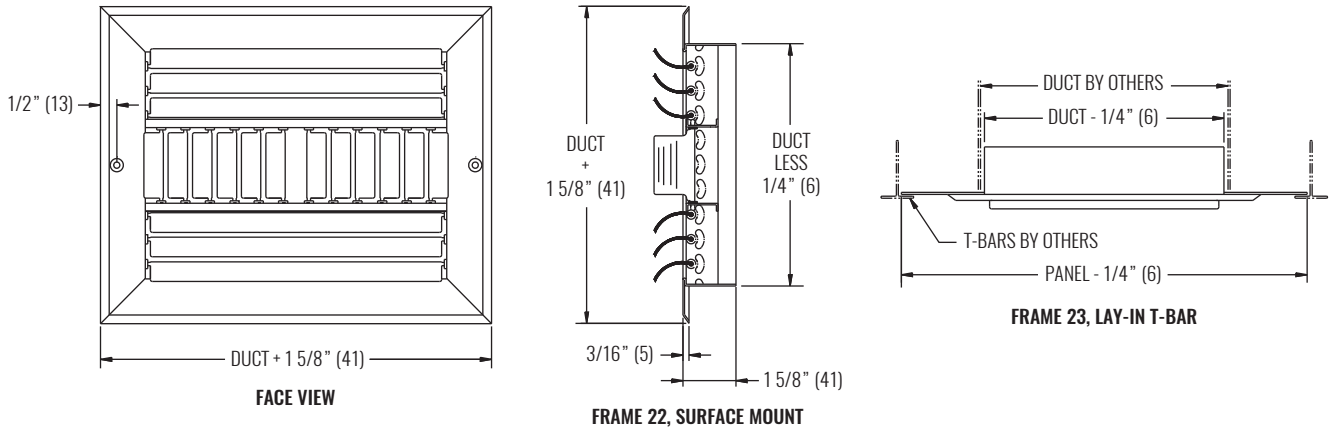

NOTES: Dimensions in parentheses are millimeters (mm).

PERFORMANCE DATA

SIZE	PERFORMANCE									
	NOMINAL SIZE	NC (< 25)				NC (25 - 40)				
CFM		1-WAY THROW (ft)	2-WAY THROW (ft)	3-WAY THROW (ft)	4-WAY THROW (ft)	CFM	1-WAY THROW (ft)	2-WAY THROW (ft)	2-WAY THROW (ft)	3-WAY THROW (ft)
8"x4"	44 - 82	13 - 18	14 - 16	9 - 14	9 - 13	86 - 147	19 - 32	17 - 28	14 - 24	13 - 23
6"x6"	50 - 94	13 - 24	11 - 21	10 - 18	9 - 17	99 - 168	25 - 37	22 - 35	19 - 31	18 - 27
8"x6"	75 - 125	13 - 21	11 - 18	9 - 16	9 - 15	131 - 224	22 - 38	19 - 33	17 - 28	15 - 26
10"x6"	83 - 155	14 - 23	12 - 20	11 - 17	10 - 16	162 - 278	24 - 41	21 - 36	18 - 31	17 - 29
8"x8"	89 - 166	14 - 27	13 - 24	11 - 20	10 - 19	174 - 298	28 - 48	25 - 42	21 - 36	20 - 34
12"x6"	100 - 184	15 - 24	13 - 21	11 - 18	10 - 17	193 - 330	25 - 43	22 - 38	19 - 33	18 - 30
12"x8"	133 - 245	16 - 27	14 - 24	12 - 20	11 - 19	256 - 439	28 - 48	25 - 42	21 - 36	20 - 34
10"x10"	139 - 256	16 - 29	14 - 26	12 - 22	11 - 21	267 - 458	31 - 53	27 - 46	23 - 40	22 - 37
12"x12"	200 - 361	18 - 32	15 - 28	13 - 24	12 - 22	376 - 646	33 - 57	29 - 49	25 - 42	23 - 40
14"x14"	272 - 482	19 - 34	17 - 29	14 - 25	13 - 23	502 - 862	35 - 60	31 - 53	26 - 45	24 - 42
16"x16"	356 - 617	20 - 35	18 - 31	15 - 26	14 - 25	643 - 1104	37 - 63	32 - 55	28 - 47	26 - 44
18"x18"	450 - 767	22 - 37	19 - 32	16 - 28	15 - 26	798 - 1372	38 - 66	34 - 58	29 - 50	27 - 46

SEE BACK SUPPLEMENT FOR DESIGN INFORMATION

NOTES: Information shown is abbreviated. See website for complete information. Throw value ranges are given for isothermal conditions, unless otherwise noted, and a terminal velocity of 50 FPM (0.25 m/s). NC ranges are based on octave band 2 - 7 sound power levels minus a room absorption of 10dB, re 10⁻¹² Watts. Data was obtained from tests conducted in accordance with ANSI/ASHRAE Standard 70, ISO Standard 5219, and ISO Standard 3741.