

MODEL

- AFQ - Corner round, low velocity displacement diffuser

FEATURES

- 20 gauge front panel
- Horizontal, low velocity discharge at floor level
- Corner installation with a 90° supply angle
- Round duct connection with integral gasket on top or bottom of the diffuser

UNIT SIZES¹

- 8"x23"
- 10"x23"
- 12"x31"
- 14"x47"
- 16"x47"
- 19"x59"
- 24"x71"
- 36"x71"

INLET SIZES

- Round: 4", 5", 6", 8", 10", 12", 16", 20", 24"

COMPATIBLE OPTIONS AND ACCESSORIES

- Flat face
- Stainless steel (AISI 316) design²
- 16 gauge front panel
- Duct cover (solid or perforated)
- Installation base (2", 4", 6")
- Vinyl trim in white or black
- Metal trim (painted to match)

NOTES: Finish code 90 (polished) not available with material code GS (steel).

¹ See Krueger's selection software for additional sizes.

² Material code SS (316 stainless steel) not available with front panel thickness code 16 (16 gauge). Material code SS (316 stainless steel) only available with finish code 90 (polished). If material code SS (stainless steel) is selected, the duct cover and installation base, if selected will be stainless steel.

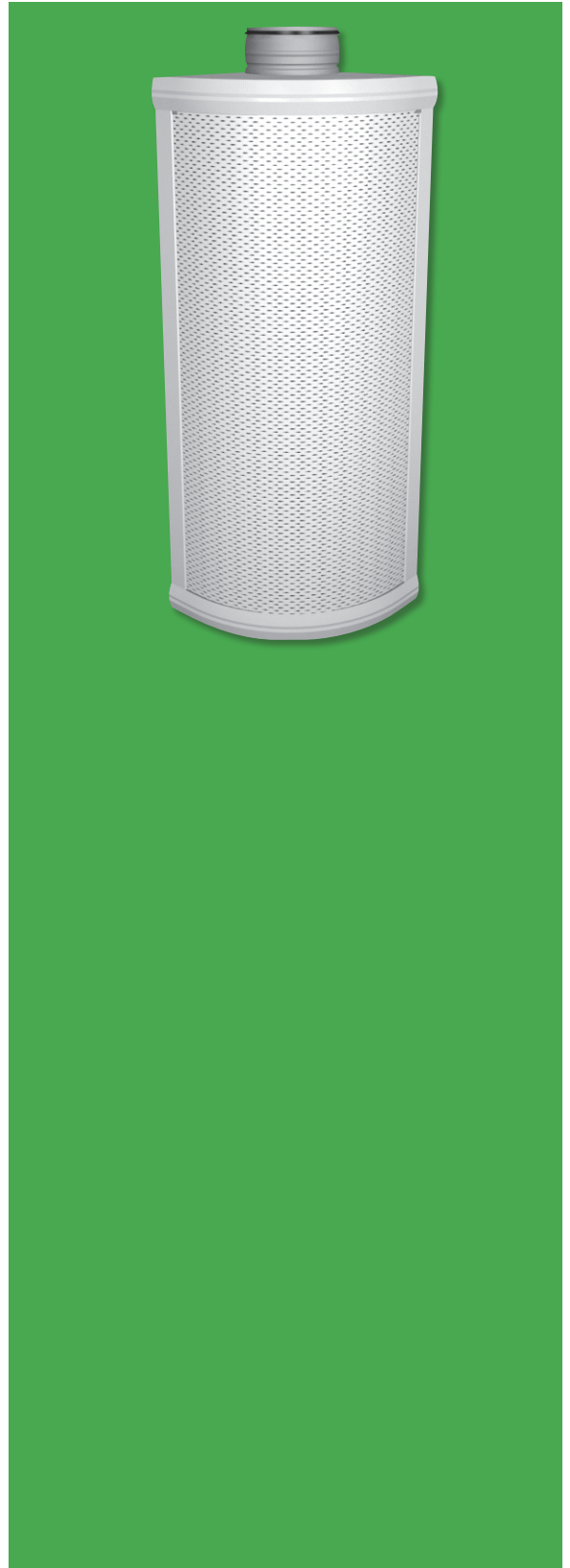

DISPLACEMENT VENTILATION

AFQ



DIMENSIONAL DATA

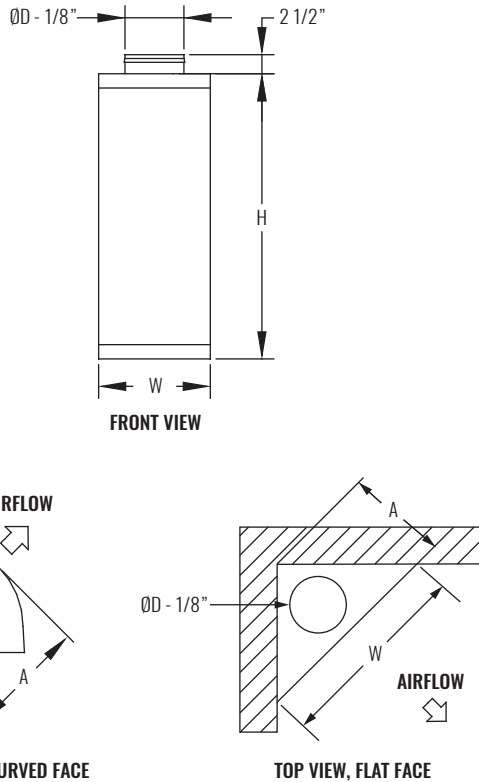

AFQ CURVED-FACE DIMENSIONS				
SIZE W x H	W	H	A	ØD
8" x 23"	8 1/16"	23 5/8"	8 13/16"	4"
10" x 23"	9 1/4"	23 5/8"	10 1/16"	5"
12" x 31"	10 13/16"	31 1/2"	11 3/4"	6"
14" x 47"	13"	47 1/4"	14"	8"
16" x 47"	15 3/8"	47 1/4"	16 7/16"	10"
19" x 59"	18 11/16"	59 1/16"	19 9/16"	12"
24" x 71"	23 1/16"	70 7/8"	24 1/4"	16"
29" x 71"	28 9/16"	70 7/8"	29 13/16"	20"
36" x 71"	35 1/16"	70 7/8"	36 7/16"	24"

AFQ FLAT-FACE DIMENSIONS				
SIZE W x H	W	H	A	ØD
24" x 24"	24"	24"	12"	8"
24" x 36"	24"	36"	12"	8"
24" x 48"	24"	48"	12"	8"
24" x 60"	24"	60"	12"	8"
24" x 72"	30"	72"	12"	8"
30" x 24"	30"	24"	15"	8", 10"
30" x 36"	30"	36"	15"	8", 10"
30" x 48"	30"	48"	15"	10"
30" x 60"	30"	60"	15"	10"
30" x 72"	36"	72"	15"	10"
36" x 24"	36"	24"	18"	10", 12"
36" x 36"	36"	36"	18"	12"
36" x 48"	36"	48"	18"	12"
36" x 60"	36"	60"	18"	12"
36" x 72"	36"	72"	18"	12"

PERFORMANCE AND DESIGN DATA

SIZE	PERFORMANCE		
	NOMINAL W x H	CFM RANGE	NC RANGE
8" x 23"	53 - 150	9 - 30	5.3 - 9.9
10" x 23"	53 - 150	9 - 30	5.3 - 9.9
12" x 31"	106 - 250	11 - 28	5.9 - 9.9
14" x 47"	212 - 475	2 - 30	7.2 - 11.2
16" x 47"	212 - 600	11 - 30	5.9 - 9.2
19" x 59"	297 - 775	14 - 29	7.9 - 11.8
24" x 71"	636 - 1400	9 - 30	9.9 - 15.1
29" x 71"	848 - 1900	9 - 30	10.5 - 16.5
36" x 71"	1060 - 2575	9 - 30	10.5 - 17.8

DESIGN	
PARAMETERS	COOLING
SUPPLY AIR TEMPERATURE	65 - 68°F
RECOMMENDED FACE VELOCITY	40 FPM
MAX FLOOR COVERAGE DISTANCE	30 ft

NOTES: Information shown is abbreviated. See website for complete information. Performance shown is based on the following operating conditions: 75°F, 50% relative humidity room design temperature. The "Near Zone Range" provides the distance in feet, measured from the face of the diffuser to where the discharge air drops down to 1" above floor level. Units are tested in accordance with the following standards: Air Flow Rate EN-ISO 5167-1 and Sound Power Level EN-ISO 7235.

© Copyright Krueger 2018