

MODEL

- KHFP - Horizontal standard fan coil unit, concealed with plenum

FEATURES

- Galvanized steel construction
- 1/2" thick fiberglass, foil faced, or cellular insulation
- 1 1/2" duct discharge collar
- Four point hanger mounting brackets
- Integral filter rack with 1" throwaway or MERV8 filter
- Integral rear ducted return, field reversible to bottom return
- Bottom return (optional)
- Telescoping bottom panels (optional)

COILS

- Cooling - chilled water (3, 4, or 5 rows) or DX (3 or 4 rows)
- Heating - hot water (1 or 2 row), reheat or preheat position
- 6 total rows of cooling and heating coils maximum
- 3/8" O.D. seamless copper tubes (0.012" tube wall thickness)
- 1/2" O.D. seamless copper tubes (0.016" or 0.025 tube wall thickness)
- Stainless steel coil casing (optional)
- High efficiency aluminum fin surface
- Left or right hand, same or opposite side connections
- Removable for service
- Manual air vents
- Automatic air vents (optional)

DRAIN PANS

- Single wall, galvanized steel or stainless steel, externally insulated - fire retardant and antimicrobial
- Positively sloped to drain connection
- Removable, field reversible
- Condensate overflow switch (optional)
- Auxiliary drain pan, galvanized or stainless steel (optional)
- 7/8" O.D. primary drain connection (3/4" MPT for stainless steel pan)
- 5/8" O.D. secondary drain connection (3/8" MPT for stainless steel pan)

FAN/MOTOR ASSEMBLIES

- Forwardly curved, DWDI centrifugal type
- 115, 208-230, 220 & 277V, 1-phase, 3-speed PSC motors
- 115, 208-230, 220 & 277V, 1-phase EC motors
- Quick disconnect motor connections
- Removable fan/motor deck for service

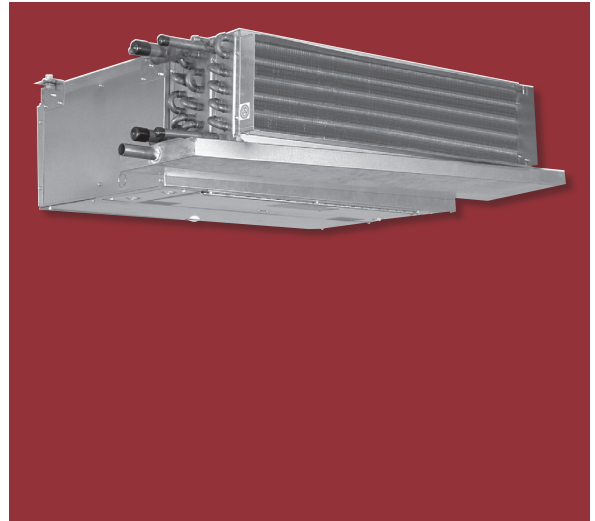

ELECTRICAL

- Electrical junction box for field wiring terminations
- Terminal block for field connections
- Unit and remote mounted three speed fan switches (optional)
- Bottom hinged electrical enclosure (optional)
- SCR fan speed controller (optional)
- Main fusing (optional)
- Disconnect switch, toggle or door interlocking (optional)
- Electric reheat available
- Silent electric heat relays and fan relay (optional)

PIPING PACKAGES

- Factory assembled, shipped loose for field installation
- 1/2" and 3/4" piping size
- 2-way and 3-way 2 position or floating point control valves
- Isolation ball valves with memory stop
- Automatic fixed flow control (optional)
- Unions and P/T ports (optional)
- Remote mounted analog, digital display or programmable thermostats

CERTIFICATIONS

- cETL Listed Electric Heat Units - Adherence to UL/ANSI Standard 1995
- AHRI 440 certified performance data

WEB SEARCH: KHFP



DIMENSIONAL DATA

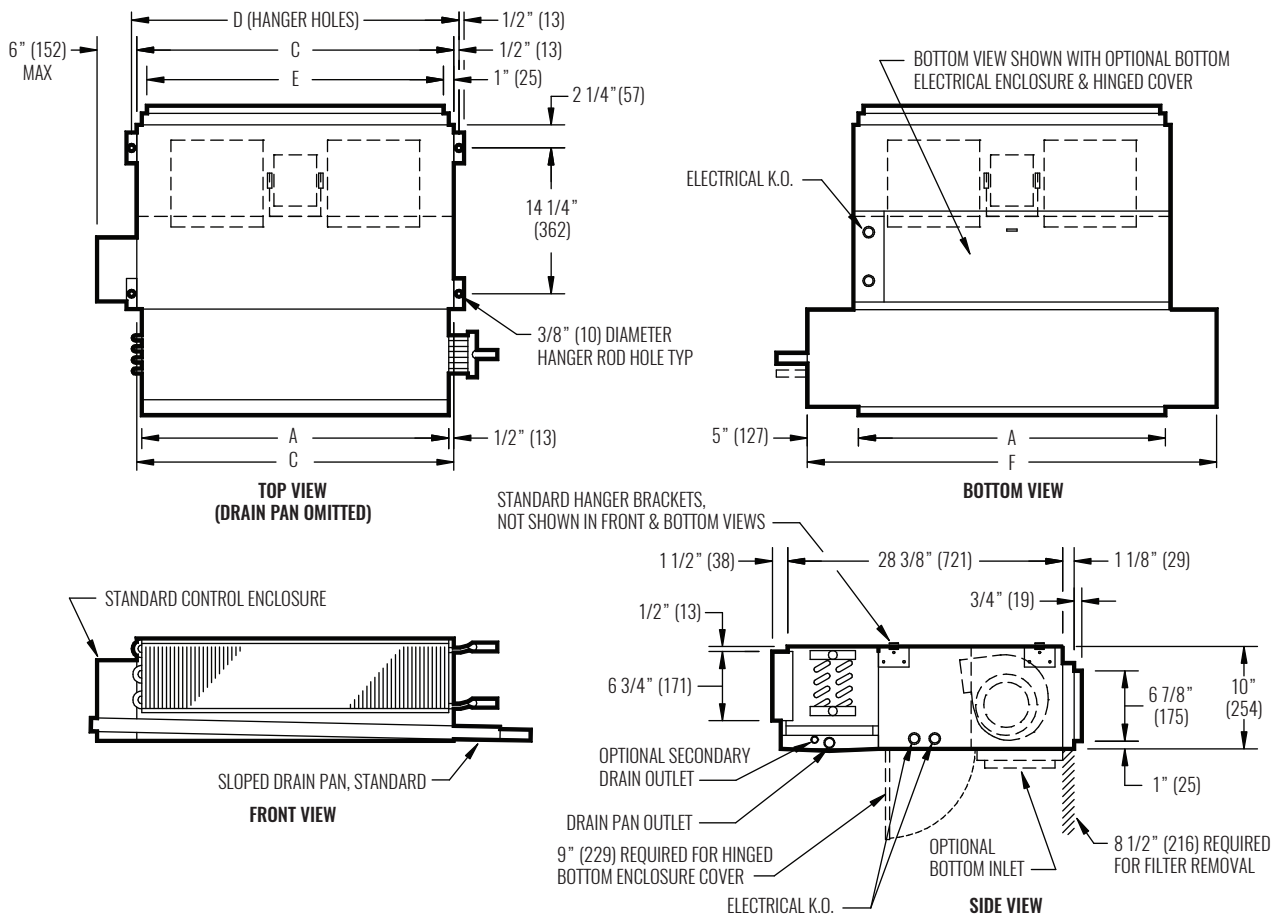

NOTE: Left hand coil shown, right hand is available. Provide access clearance for electrical enclosure per local and national electrical code requirements. Dimensions in parentheses are in millimeters (mm). See table below for dimensional references.

PERFORMANCE AND DIMENSIONAL DATA

SIZE	PERFORMANCE			DIMENSIONS				
	UNIT	CFM RANGE	TOTAL COOLING CAPACITY RANGE (MBH)	HEATING CAPACITY RANGE (MBH)	A	C	D	E
20	249 - 269	5 - 8	13 - 21	20" (508)	21" (533)	22" (559)	19" (483)	30" (762)
25	385 - 403	9 - 10	18 - 30	26" (660)	27" (686)	28" (711)	25" (635)	36" (914)
30	556 - 604	10 - 14	23 - 40	30" (762)	31" (787)	32" (813)	29" (737)	40" (1016)
40	702 - 743	15 - 21	29 - 30	40" (1016)	41" (1041)	42" (1067)	39" (991)	50" (1270)
50	1011 - 1103	19 - 29	39 - 69	50" (1270)	51" (1295)	52" (1321)	49" (1245)	60" (1524)
60	1230 - 1355	21 - 33	48 - 85	60" (1524)	61" (1549)	62" (1575)	59" (1499)	70" (1778)

NOTES: Information shown is abbreviated. See website for complete information. Data is based on 115/1/60 3-speed PSC motor on high fan speed with 0.05" ESP. Cooling coil: 75°F DB and 63°F WB EAT, 45°F EWT, 55°F LWT. Heating coil: 70°F DB EAT, 180°F EWT, 160°F LWT. CFM and coil performance ranges will vary depending on coil combination selected.