

9S80P

Stainless Steel Return Diffuser, Perforated Face

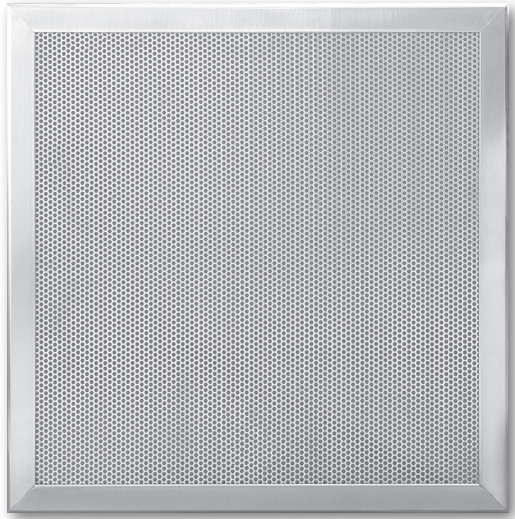

INTRODUCTION

The 9S80P series stainless steel perforated diffusers feature 51% free-area and are used for return applications where bar-style grilles are not required. They are available for surface mount or lay-in T-bar applications.

MODEL

9S80P - Perforated Return Grille

FEATURES

- 3/16" Holes on 1/4" staggered centers (51% free area)
- 304 Stainless steel construction (316 optional)
- Countersunk screw holes in mounting frame (optional)
- Standard finish is 90 - #4 Satin Polish or 44 - British White

ACCESSORIES

- Stainless steel OBD welded to unit, adjustable from face of grille (model 9OBD)
- Plaster frame (model 98PF)
- Square to round adapter (model 9SRA)

DIMENSIONAL DATA

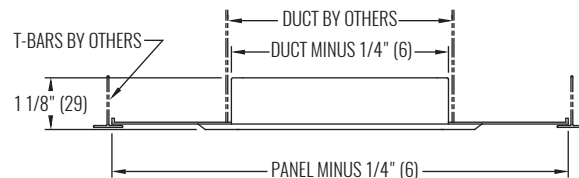
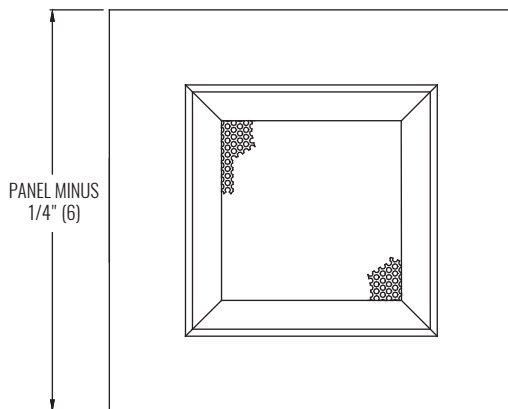
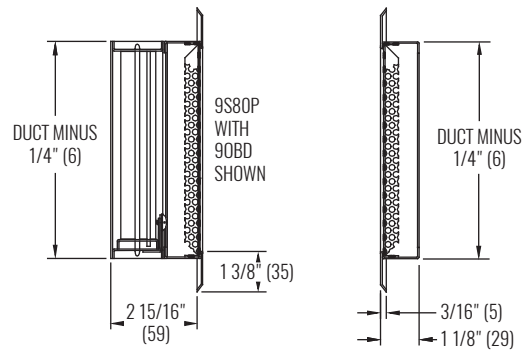
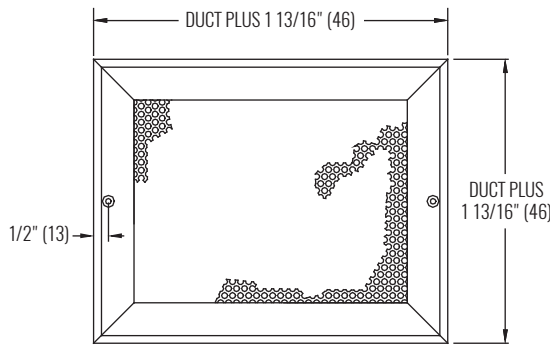

NOTE: Dimensions in parentheses are millimeters (mm).

PERFORMANCE DATA | SQUARE NECK, NO DAMPER

IP DATA					SOUND	METRIC DATA				
NOM DUCT	DUCT AREA	NECK VEL	AIR FLOW	Ps		NOM DUCT	DUCT AREA	NECK VEL	AIR FLOW	Ps
in	sq ft	fpm	cfm	in wg	NC	cm	sq m	m/s	l/s	Pa
6 x 6	0.250	300	70	-.030	<20	15.2 x 15.2	0.023	1.52	33	-7.470
		400	90	-.050	<20			2.03	42	-12.450
		500	110	-.070	<20			2.54	52	-17.430
		600	130	-.110	<20			3.05	61	-27.390
		700	150	-.140	<20			3.56	71	-34.860
		800	180	-.190	<20			4.06	85	-47.310
		1000	220	-.290	20			5.08	104	-72.210
		1200	260	-.420	25			6.10	123	-104.580
8 x 8	0.444	300	120	-.030	<20	20.3 x 20.3	0.041	1.52	57	-7.470
		400	160	-.050	<20			2.03	76	-12.450
		500	200	-.070	<20			2.54	94	-17.430
		600	240	-.110	<20			3.05	113	-27.390
		700	280	-.140	<20			3.56	132	-34.860
		800	320	-.190	<20			4.06	151	-47.310
		1000	400	-.290	23			5.08	189	-72.210
		1200	480	-.420	27			6.10	227	-104.580
12 x 6	0.500	300	140	-.030	<20	30.5 x 15.2	0.046	1.52	66	-7.470
		400	180	-.050	<20			2.03	85	-12.450
		500	230	-.070	<20			2.54	109	-17.430
		600	270	-.110	<20			3.05	127	-27.390
		700	320	-.140	<20			3.56	151	-34.860
		800	360	-.190	<20			4.06	170	-47.310
		1000	450	-.290	23			5.08	212	-72.210
		1200	540	-.420	28			6.10	255	-104.580
10 x 10	0.694	300	190	-.030	<20	25.4 x 25.4	0.064	1.52	90	-7.470
		400	260	-.050	<20			2.03	123	-12.450
		500	320	-.070	<20			2.54	151	-17.430
		600	390	-.110	<20			3.05	184	-27.390
		700	450	-.140	<20			3.56	212	-34.860
		800	510	-.190	<20			4.06	241	-47.310
		1000	640	-.290	25			5.08	302	-72.210
		1200	770	-.420	29			6.10	363	-104.580
18 x 6	0.750	300	210	-.030	<20	45.7 x 15.2	0.070	1.52	99	-7.470
		400	280	-.050	<20			2.03	132	-12.450
		500	340	-.070	<20			2.54	160	-17.430
		600	410	-.110	<20			3.05	193	-27.390
		700	480	-.140	<20			3.56	227	-34.860
		800	550	-.190	20			4.06	260	-47.310
		1000	690	-.290	25			5.08	326	-72.210
		1200	830	-.420	30			6.10	392	-104.580
12 x 12	1.000	300	280	-.030	<20	30.5 x 30.5	0.093	1.52	132	-7.470
		400	380	-.050	<20			2.03	179	-12.450
		500	470	-.070	<20			2.54	222	-17.430
		600	560	-.110	<20			3.05	264	-27.390
		700	660	-.140	<20			3.56	311	-34.860
		800	750	-.190	21			4.06	354	-47.310
		1000	940	-.290	27			5.08	444	-72.210
		1200	1130	-.420	31			6.10	533	-104.580

NOTES: NC values are based on Octave Band 2 - 7 sound power levels minus a room absorption of 10dB. Dash (-) in space denotes an NC or dB value of less than 10. Data was obtained from tests conducted in accordance with ANSI/ASHRAE Standard 70-81.

GRILLES | STAINLESS STEEL

PERFORMANCE DATA | SQUARE NECK, NO DAMPER

		IP DATA				SOUND	METRIC DATA				
NOM DUCT	DUCT AREA	NECK VEL	AIR FLOW	Ps	NOM DUCT		DUCT AREA	NECK VEL	AIR FLOW	Ps	
in	sq ft	fpm	cfm	in wg	NC	cm	sq m	m/s	l/s	Pa	
14 x 14	1.361	300	390	-0.030	<20	36 x 36	0.126	1.52	184	-7.470	
		400	520	-0.050	<20			2.03	245	-12.450	
		500	640	-0.070	<20			2.54	302	-17.430	
		600	770	-0.110	<20			3.05	363	-27.390	
		700	900	-0.140	<20			3.56	425	-34.860	
		800	1030	-0.190	22			4.06	486	-47.310	
		1000	1290	-0.290	28			5.08	609	-72.210	
		1200	1550	-0.420	32			6.10	732	-104.580	
18 x 12	1.500	300	430	-0.030	<20	45.7 x 30.5	0.139	1.52	203	-7.470	
		400	570	-0.050	<20			2.03	269	-12.450	
		500	710	-0.070	<20			2.54	335	-17.430	
		600	850	-0.110	<20			3.05	401	-27.390	
		700	1000	-0.140	20			3.56	472	-34.860	
		800	1140	-0.190	23			4.06	538	-47.310	
		1000	1420	-0.290	28			5.08	670	-72.210	
		1200	1710	-0.420	33			6.10	807	-104.580	
24 x 10	1.667	300	470	-0.030	<20	61.0 x 25.4	0.155	1.52	222	-7.470	
		400	630	-0.050	<20			2.03	297	-12.450	
		500	790	-0.070	<20			2.54	373	-17.430	
		600	950	-0.110	<20			3.05	448	-27.390	
		700	1110	-0.140	20			3.56	524	-34.860	
		800	1260	-0.190	23			4.06	595	-47.310	
		1000	1580	-0.290	29			5.08	746	-72.210	
		1200	1890	-0.420	33			6.10	892	-104.580	
24 x 12	2.000	300	570	-0.030	<20	61.0 x 30.5	0.186	1.52	269	-7.470	
		400	760	-0.050	<20			2.03	359	-12.450	
		500	950	-0.070	<20			2.54	448	-17.430	
		600	1140	-0.110	<20			3.05	538	-27.390	
		700	1340	-0.140	21			3.56	632	-34.860	
		800	1530	-0.190	24			4.06	722	-47.310	
		1000	1910	-0.290	30			5.08	901	-72.210	
		1200	2290	-0.420	34			6.10	1081	-104.580	
30 x 12	2.500	300	720	-0.030	<20	76.2 x 30.5	0.232	1.52	340	-7.470	
		400	960	-0.050	<20			2.03	453	-12.450	
		500	1200	-0.070	<20			2.54	566	-17.430	
		600	1430	-0.110	<20			3.05	675	-27.390	
		700	1670	-0.140	22			3.56	788	-34.860	
		800	1910	-0.190	25			4.06	901	-47.310	
		1000	2390	-0.290	31			5.08	1128	-72.210	
		1200	2870	-0.420	35			6.10	1354	-104.580	
24 x 24	4.000	300	1160	-0.030	<20	61.0 x 61.0	0.372	1.52	547	-7.470	
		400	1550	-0.050	<20			2.03	732	-12.450	
		500	1940	-0.070	<20			2.54	916	-17.430	
		600	2330	-0.110	20			3.05	1100	-27.390	
		700	2710	-0.140	24			3.56	1279	-34.860	
		800	3100	-0.190	27			4.06	1463	-47.310	
		1000	3880	-0.290	33			5.08	1831	-72.210	
		1200	4650	-0.420	37			6.10	2195	-104.580	

NOTES: NC values are based on Octave Band 2 - 7 sound power levels minus a room absorption of 10dB. Dash (-) in space denotes an NC or dB value of less than 10. Data was obtained from tests conducted in accordance with ANSI/ASHRAE Standard 70-81.

PERFORMANCE DATA | SQUARE NECK, NO DAMPER

IP DATA					SOUND	METRIC DATA				
NOM DUCT	DUCT AREA	NECK VEL	AIR FLOW	Ps		NOM DUCT	DUCT AREA	NECK VEL	AIR FLOW	Ps
in	sq ft	fpm	cfm	in wg		NC	cm	sq m	m/s	l/s
30 x 30	6.250	300	1830	-.030	<20	76.2 x 76.2	0.581	1.52	864	-7.470
		400	2440	-.050	<20			2.03	1152	-12.450
		500	3050	-.070	<20			2.54	1439	-17.430
		600	3660	-.110	22			3.05	1727	-27.390
		700	4270	-.140	26			3.56	2015	-34.860
		800	4880	-.190	29			4.06	2303	-47.310
		1000	6090	-.290	35			5.08	2874	-72.210
		1200	7310	-.420	39	6.10	3450	-104.580		
48 x 24	8.000	300	2340	-.030	<20	121.9 x 61.0	0.743	1.52	1104	-7.470
		400	3130	-.050	<20			2.03	1477	-12.450
		500	3910	-.070	<20			2.54	1845	-17.430
		600	4690	-.110	23			3.05	2213	-27.390
		700	5470	-.140	27			3.56	2582	-34.860
		800	6250	-.190	30			4.06	2950	-47.310
		1000	7810	-.290	36			5.08	3686	-72.210
		1200	9380	-.420	40	6.10	4427	-104.580		
38 x 38	10.028	300	2950	-.030	<20	96.5 x 96.5	0.932	1.52	1392	-7.470
		400	3930	-.050	<20			2.03	1855	-12.450
		500	4920	-.070	20			2.54	2322	-17.430
		600	5900	-.110	24			3.05	2784	-27.390
		700	6880	-.140	28			3.56	3247	-34.860
		800	7860	-.190	31			4.06	3710	-47.310
		1000	9830	-.290	37			5.08	4639	-72.210
		1200	11800	-.420	41	6.10	5569	-104.580		
48 x 36	12.000	300	3530	-.030	<20	121.9 x 91.4	1.115	1.52	1666	-7.470
		400	4710	-.050	<20			2.03	2223	-12.450
		500	5890	-.070	21			2.54	2780	-17.430
		600	7070	-.110	25			3.05	3337	-27.390
		700	8250	-.140	29			3.56	3894	-34.860
		800	9430	-.190	32			4.06	4450	-47.310
		1000	11780	-.290	38			5.08	5560	-72.210
		1200	14140	-.420	42	6.10	6673	-104.580		
48 x 42	14.000	300	4130	-.030	<20	121.9 x 106.7	1.301	1.52	1949	-7.470
		400	5510	-.050	<20			2.03	2600	-12.450
		500	6880	-.070	21			2.54	3247	-17.430
		600	8260	-.110	26			3.05	3898	-27.390
		700	9640	-.140	29			3.56	4550	-34.860
		800	11010	-.190	33			4.06	5196	-47.310
		1000	13770	-.290	38			5.08	6499	-72.210
		1200	16520	-.420	43	6.10	7797	-104.580		
48 x 48	16.000	300	4730	-.030	<20	121.9 x 121.9	1.486	1.52	2232	-7.470
		400	6300	-.050	<20			2.03	2973	-12.450
		500	7880	-.070	22			2.54	3719	-17.430
		600	9450	-.110	26			3.05	4460	-27.390
		700	11030	-.140	30			3.56	5206	-34.860
		800	12600	-.190	33			4.06	5947	-47.310
		1000	15750	-.290	39			5.08	7433	-72.210
		1200	18900	-.420	43	6.10	8920	-104.580		

NOTES: NC values are based on Octave Band 2 - 7 sound power levels minus a room absorption of 10dB. Dash (-) in space denotes an NC or dB value of less than 10. Data was obtained from tests conducted in accordance with ANSI/ASHRAE Standard 70-81.

GRILLES | STAINLESS STEEL

9S80P

Stainless Steel Return Diffuser, Perforated Face



ENGINEERING SPECIFICATION & CONFIGURATION

9S80P

The return grille shall be a Krueger model 9S80P. This grille must have 3/16" holes on 1/4" staggered centers resulting in a 51% free area face constructed of 20 gage 304 stainless steel. The frame of the grille must be constructed of 20 gage 304 stainless steel with countersunk screw holes (#6x1 1/4" stainless sheet metal screws provided by manufacturer). This frame must also produce a border of 1 3/8" around all sides of the grille with mitered corners. Optional 304 stainless steel damper available made of 20 gage stainless steel welded to the return grille and operable from the face.

Optional 316 stainless steel construction available.

FINISH

The finish shall be 90 - #4 Satin Polish, obtained by finishing with a 120-grit abrasive, or 44 - British White.

1. SERIES: (XXXXX)

9S80P - Perforated Return Grille

2. WIDTH: (XX)

4" - 48" in 1" Increments

3. HEIGHT: (XX)

4" - 60" in 1" Increments

4. MATERIAL: (XXX)

304 - Stainless Steel Grade 304

316 - Stainless Steel Grade 316

5. FRAME STYLE: (XXX)

F22 - Surface Mount

F23 - Lay-in T-Bar

6. PANEL: (XX)x(XX)

None

24"x24" *

24"x48" *

7. FASTENING METHOD: (XX)

00 - No Screw Holes

01 - Countersunk Screw Holes **

8. DAMPER: (XX)

00 - No Damper

01 - Stainless Steel OBD †

9. ACCESSORIES: (XX) (XX)

00 - No Accessories

01 - Plaster Frame

XX - Square to Round Adapter ‡

(Specify size from 04 - 18" in increments of 2", depending on neck size)

10. FINISH: (XX)

90 - #4 Satin Polish

44 - British White

Maximum single unit size is 48"x60".

* Only available with Frame 23.

** Unit shipped with #6x1 1/4" stainless steel sheet metal screws.

† Damper is welded to unit.

‡ Square to Round Adapter is not available with OBD.

SAMPLE CONFIGURATION: 9S80P - 26x26 - 316 - F22 - NONE - 01 - 00 - 02 - 00 - 90