

JOB NAME _____
 ARCHITECT _____
 ENGINEER _____
 CONTRACTOR _____
 LOCATION _____

SUBMITTAL SHEET
 Form Number DS3612.4 Effective Date 2/24
 Replaces DS3612.3

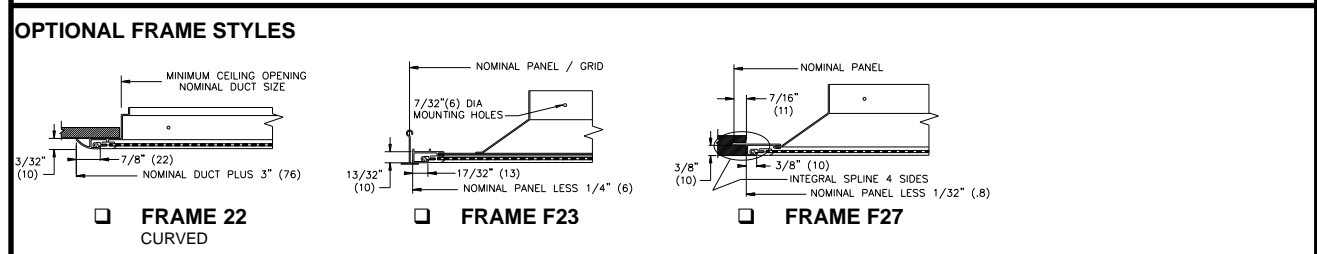

1190 / 51190 SERIES
PERFORATED RETURN WITH CONCEALED HINGE

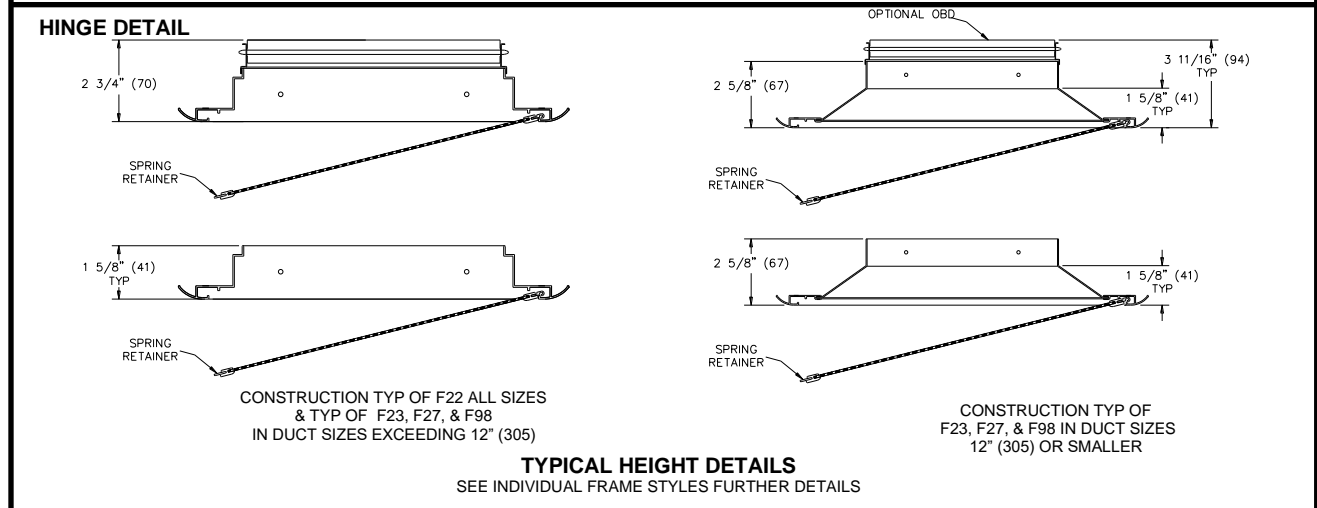
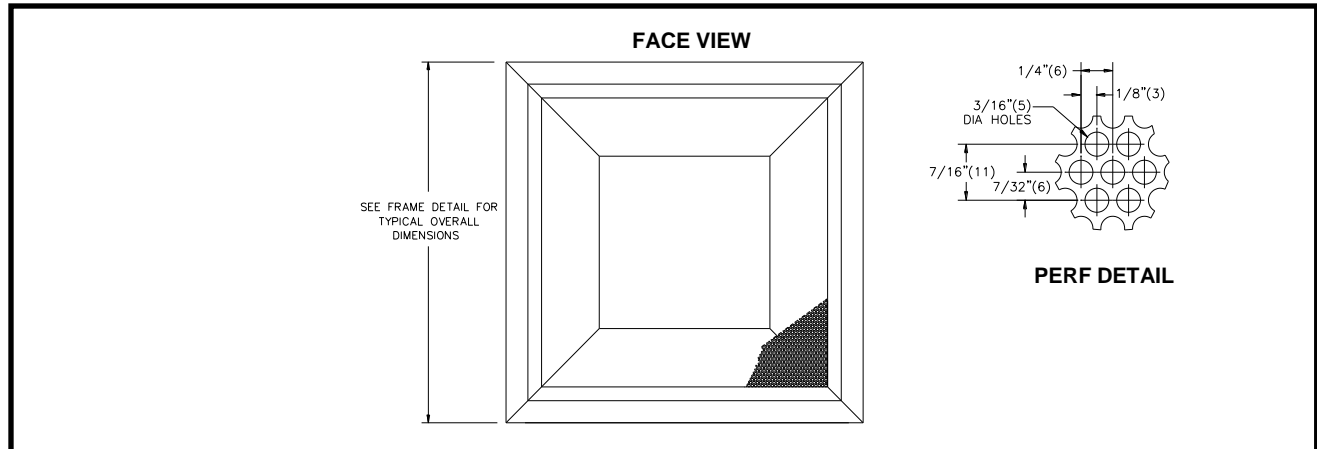

NOTES :

1. 1190 CONSTRUCTION IS STEEL WITH EXTRUDED ALUMINUM HINGE FRAME AND STEEL SPRING RETAINER.
2. 51190 CONSTRUCTION IS ALUMINUM WITH EXTRUDED ALUMINUM HINGE FRAME AND STEEL SPRING RETAINER.
3. STANDARD FINISH IS 44 WHITE
4. SEE FORM DS3601 FOR SUPPLY UNITS.

ACCESSORIES :

- 5OBD ALUMINUM OPPOSED BLADE DAMPER
- OBD STEEL OPPOSED BLADE DAMPER
- POBD PAINTED STEEL OPPOSED BLADE DAMPER

DIMENSIONS ARE SHOWN AS INCHES (MM)