

SERIES 1240
MODULAR CORE DIFFUSER - STEEL CONSTRUCTION
SUBMITTAL SHEET

FACE VIEW FR 21 IS SHOWN ABOVE
 SEE SPECIFIC FRAME STYLE FOR ALL DIMENSION DETAILS

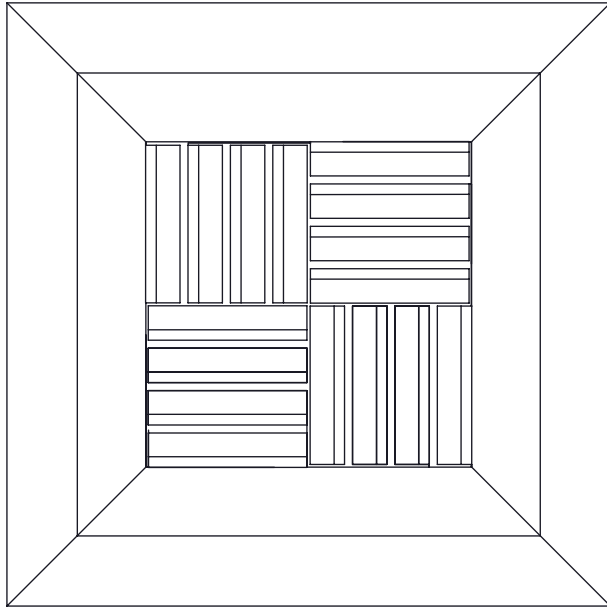
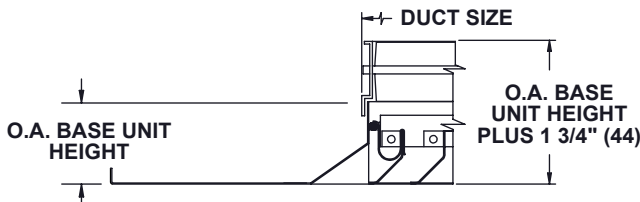
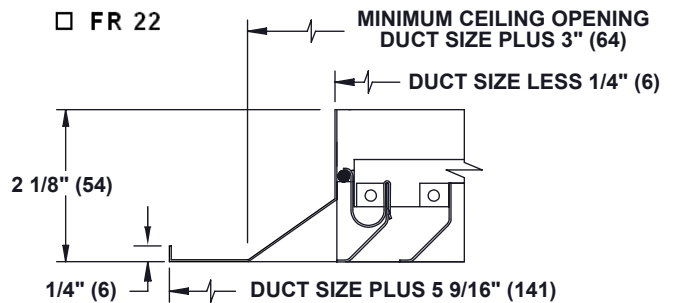
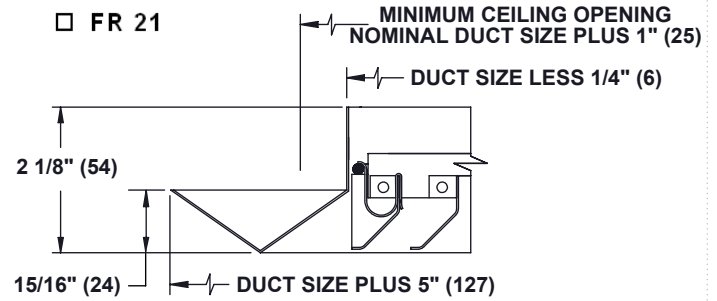
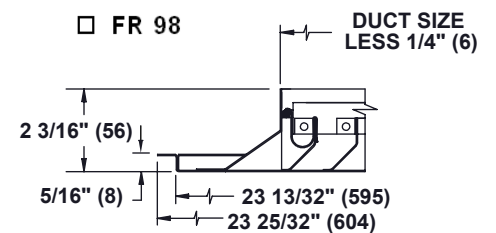
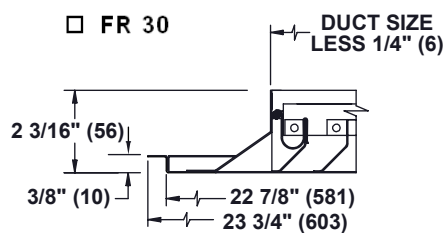
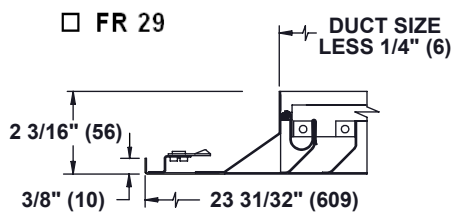
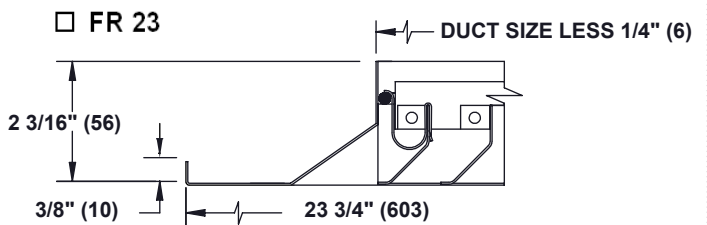

OBD1240 DETAIL
 TYPICAL OF ALL FRAME STYLES FR 23 SHOWN

NOTES:

1. Construction is 24 GA. Steel
2. Four Snap in Cores Field Adjust to Provide 1, 2, 3, or 4 Way Patterns
3. Standard Finish is 44 White

ACCESSORIES

- OBD1240 – Steel Opposed Blade Damper
- 5OBD1240 – Aluminum Opposed Blade Damper

INLET	FRAME STYLES					
	FR21	FR22	FR23	FR29	FR30	FR98
06x06 (152x152)	X	X	X	X	X	X
08x08 (203x203)	X	X	X	X	X	X
10x10 (254x254)	X	X	X	X	X	X
12x12 (305x305)	X	X	X	X	X	X
14x14 (356x356)	X	X	X	X	X	X
16x16 (406x406)	X	X	X	X	X	X
18x18 (457x457)	X	X	X	X	X	X
20x20 (508x508)	X	X	X	N/A	N/A	N/A
22x22 (559x559)	X	X	N/A	N/A	N/A	N/A
24x24 (610x610)	X	X	N/A	N/A	N/A	N/A