

## 1900 SERIES LINEAR SLOT DIFFUSER FRAME STYLE 'A' T-BAR CEILING MOUNT

JOB NAME \_\_\_\_\_  
ENGINEER \_\_\_\_\_  
CONTRACTOR \_\_\_\_\_  
TAG \_\_\_\_\_

## SUBMITTAL SHEET

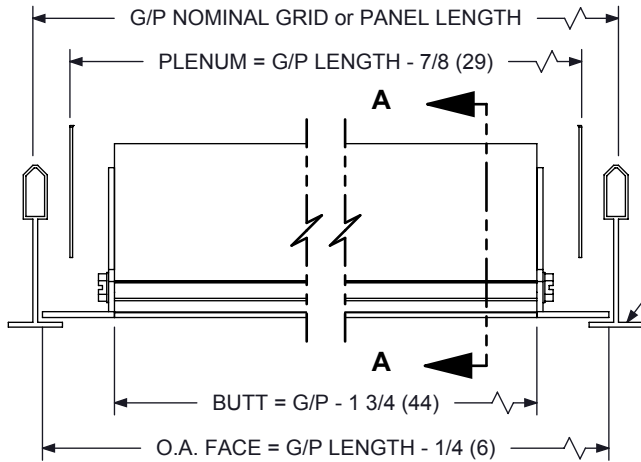

**SIDE VIEW**

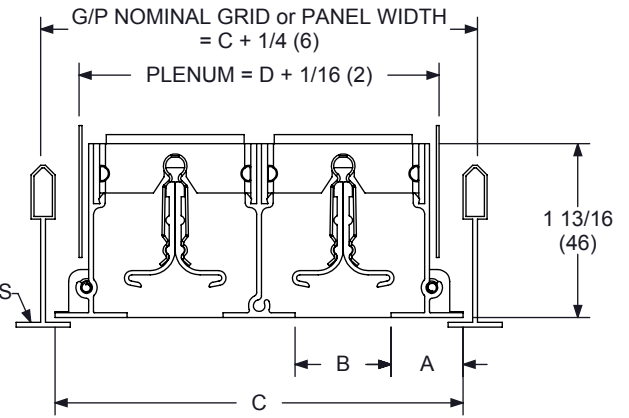

**SECTION A-A  
WITH BLADES**

1950A (1/2" SPACING)				
SLOT	A	B	C	D
1	3/4 (19)	1/2 (13)	2 (51)	1-3/8 (35)
2	3/4 (19)	1/2 (13)	3-1/4 (83)	2-5/8 (67)
3	3/4 (19)	1/2 (13)	4-1/2 (114)	3-7/8 (98)
4	3/4 (19)	1/2 (13)	5-3/4 (146)	5-1/8 (130)
5	3/4 (19)	1/2 (13)	7 (178)	6-3/8 (162)
6	3/4 (19)	1/2 (13)	8-1/4 (210)	7-5/8 (194)
7	3/4 (19)	1/2 (13)	9-1/2 (241)	8-7/8 (225)
8	3/4 (19)	1/2 (13)	10-3/4 (273)	10-1/8 (257)

1975A (3/4" SPACING)				
SLOT	A	B	C	D
1	3/4 (19)	3/4 (19)	2-1/4 (57)	1-5/8 (41)
2	3/4 (19)	3/4 (19)	3-3/4 (95)	3-1/8 (79)
3	3/4 (19)	3/4 (19)	5-1/4 (133)	4-5/8 (117)
4	3/4 (19)	3/4 (19)	6-3/4 (171)	6-1/8 (156)
5	3/4 (19)	3/4 (19)	8-1/4 (210)	7-5/8 (194)
6	3/4 (19)	3/4 (19)	9-3/4 (248)	9-1/8 (232)
7	3/4 (19)	3/4 (19)	11-1/4 (286)	10-5/8 (270)
8	3/4 (19)	3/4 (19)	12-3/4 (324)	12-1/8 (308)

1910A (1" SPACING)				
SLOT	A	B	C	D
1	3/4 (19)	1 (25)	2-1/2 (64)	1-7/8 (48)
2	3/4 (19)	1 (25)	4-1/4 (108)	3-5/8 (92)
3	3/4 (19)	1 (25)	6 (152)	5-3/8 (137)
4	3/4 (19)	1 (25)	7-3/4 (197)	7-1/8 (181)
5	3/4 (19)	1 (25)	9-1/2 (241)	8-7/8 (225)
6	3/4 (19)	1 (25)	11-1/4 (286)	10-5/8 (270)
7	3/4 (19)	1 (25)	13 (330)	12-3/8 (314)
8	3/4 (19)	1 (25)	14-3/4 (375)	14-1/8 (359)

1915A (1-1/2" Spacing)				
SLOT	A	B	C	D
1	3/4 (19)	1-1/2 (38)	3 (76)	2-3/8 (60)
2	3/4 (19)	1-1/2 (38)	5-1/4 (133)	4-5/8 (117)
3	3/4 (19)	1-1/2 (38)	7-1/2 (191)	6-7/8 (175)
4	3/4 (19)	1-1/2 (38)	9-3/4 (248)	9-1/8 (232)
1920A (2" Spacing)				
1	3/4 (19)	2 (51)	3-1/2 (89)	2-7/8 (73)
2	3/4 (19)	2 (51)	6-1/4 (159)	5-5/8 (143)
3	3/4 (19)	2 (51)	9 (229)	8-3/8 (213)
4	3/4 (19)	2 (51)	11-3/4 (298)	11-1/8 (283)

**NOTES :**

- Individual Sections Range from 12" (305) to 72" (1829) Long. Longer Units will Consist of Sections Butted Together with Alignment Pins
- See Form DS0712 for Duct Length Details
- See Form DS0711 for 1900 Boot Information
- Construction is Extruded Aluminum with Steel Clips
- Standard Finish : Straight Frame - White, Blades - Back
- Standard Finish : Curved Frame - White, Deflectors - White

**OPTIONS :**

- STEEL BLANK OFF STRIPS
- NO BLADES

**DIMENSIONS GIVEN AS  
INCHES (MM)**

## 1900 SERIES LINEAR SLOT DIFFUSER FRAME STYLE 'A' T-BAR CEILING MOUNT

JOB NAME \_\_\_\_\_  
ENGINEER \_\_\_\_\_  
CONTRACTOR \_\_\_\_\_  
TAG \_\_\_\_\_

## SUBMITTAL SHEET

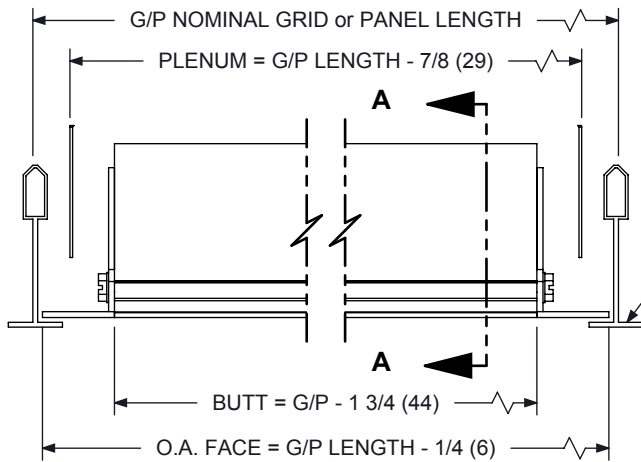

**SIDE VIEW**

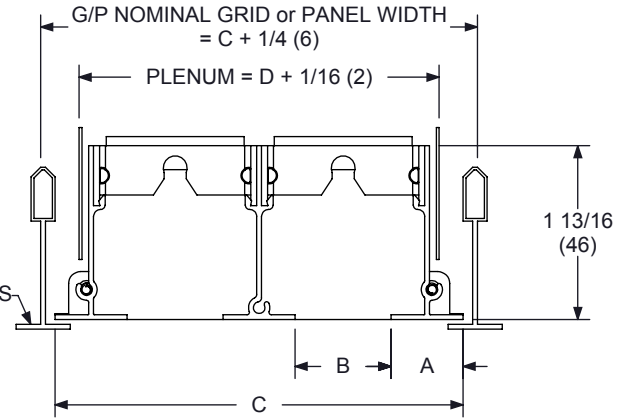

**SECTION A-A  
NO BLADES**

1950A (1/2" SPACING)				
SLOT	A	B	C	D
1	3/4 (19)	1/2 (13)	2 (51)	1-3/8 (35)
2	3/4 (19)	1/2 (13)	3-1/4 (83)	2-5/8 (67)
3	3/4 (19)	1/2 (13)	4-1/2 (114)	3-7/8 (98)
4	3/4 (19)	1/2 (13)	5-3/4 (146)	5-1/8 (130)
5	3/4 (19)	1/2 (13)	7 (178)	6-3/8 (162)
6	3/4 (19)	1/2 (13)	8-1/4 (210)	7-5/8 (194)
7	3/4 (19)	1/2 (13)	9-1/2 (241)	8-7/8 (225)
8	3/4 (19)	1/2 (13)	10-3/4 (273)	10-1/8 (257)

1975A (3/4" SPACING)				
SLOT	A	B	C	D
1	3/4 (19)	3/4 (19)	2-1/4 (57)	1-5/8 (41)
2	3/4 (19)	3/4 (19)	3-3/4 (95)	3-1/8 (79)
3	3/4 (19)	3/4 (19)	5-1/4 (133)	4-5/8 (117)
4	3/4 (19)	3/4 (19)	6-3/4 (171)	6-1/8 (156)
5	3/4 (19)	3/4 (19)	8-1/4 (210)	7-5/8 (194)
6	3/4 (19)	3/4 (19)	9-3/4 (248)	9-1/8 (232)
7	3/4 (19)	3/4 (19)	11-1/4 (286)	10-5/8 (270)
8	3/4 (19)	3/4 (19)	12-3/4 (324)	12-1/8 (308)

1910A (1" SPACING)				
SLOT	A	B	C	D
1	3/4 (19)	1 (25)	2-1/2 (64)	1-7/8 (48)
2	3/4 (19)	1 (25)	4-1/4 (108)	3-5/8 (92)
3	3/4 (19)	1 (25)	6 (152)	5-3/8 (137)
4	3/4 (19)	1 (25)	7-3/4 (197)	7-1/8 (181)
5	3/4 (19)	1 (25)	9-1/2 (241)	8-7/8 (225)
6	3/4 (19)	1 (25)	11-1/4 (286)	10-5/8 (270)
7	3/4 (19)	1 (25)	13 (330)	12-3/8 (314)
8	3/4 (19)	1 (25)	14-3/4 (375)	14-1/8 (359)

1915A (1-1/2" Spacing)				
SLOT	A	B	C	D
1	3/4 (19)	1-1/2 (38)	3 (76)	2-3/8 (60)
2	3/4 (19)	1-1/2 (38)	5-1/4 (133)	4-5/8 (117)
3	3/4 (19)	1-1/2 (38)	7-1/2 (191)	6-7/8 (175)
4	3/4 (19)	1-1/2 (38)	9-3/4 (248)	9-1/8 (232)
1920A (2" Spacing)				
1	3/4 (19)	2 (51)	3-1/2 (89)	2-7/8 (73)
2	3/4 (19)	2 (51)	6-1/4 (159)	5-5/8 (143)
3	3/4 (19)	2 (51)	9 (229)	8-3/8 (213)
4	3/4 (19)	2 (51)	11-3/4 (298)	11-1/8 (283)

**NOTES :**

- Individual Sections Range from 12" (305) to 72" (1829) Long. Longer Units will Consist of Sections Butted Together with Alignment Pins
- See Form DS0712 for Duct Length Details
- See Form DS0711 for 1900 Boot Information
- Construction is Extruded Aluminum with Steel Clips
- Standard Finish : Straight Frame - White, Blades - Back
- Standard Finish : Curved Frame - White, Deflectors - White

**OPTIONS :**

- STEEL BLANK OFF STRIPS
- WITH BLADES

**DIMENSIONS GIVEN AS  
INCHES (MM)**