

## 1900 SERIES LINEAR SLOT DIFFUSER

FRAME STYLE 'C'

SURFACE MOUNT WITH CONCEALED FASTENING

JOB NAME \_\_\_\_\_  
 ENGINEER \_\_\_\_\_  
 CONTRACTOR \_\_\_\_\_  
 TAG \_\_\_\_\_

## SUBMITTAL SHEET

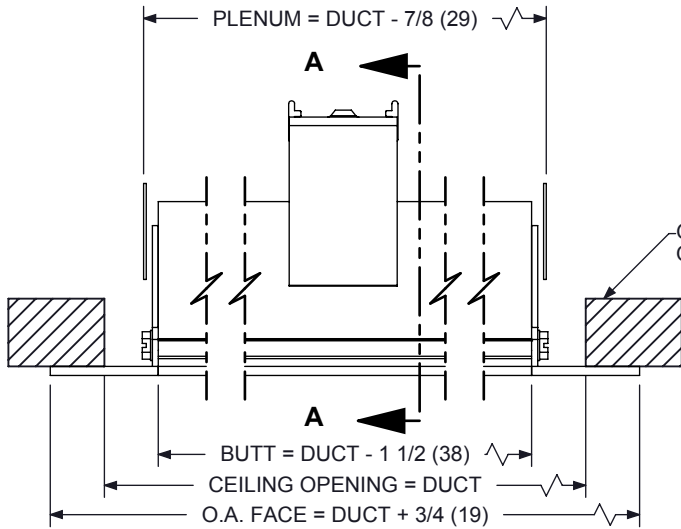

**SIDE VIEW**

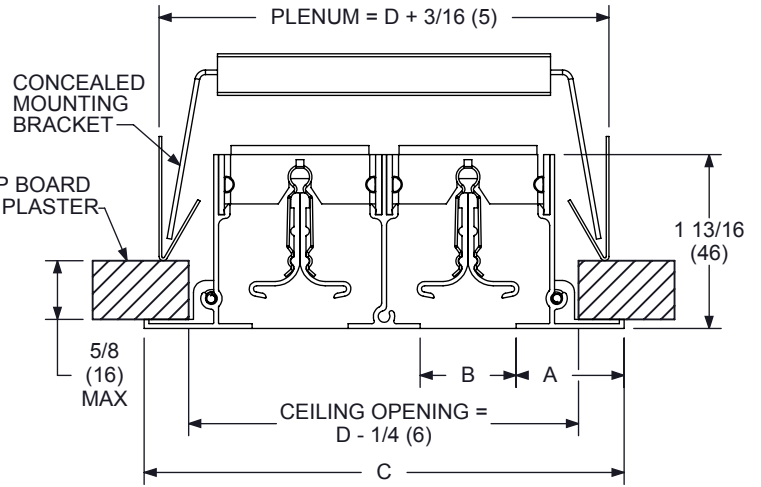

**SECTION A-A WITH BLADES**

1950C (1/2" Spacing)				
SLOT	A	B	C	D
1	1-1/8 (29)	1/2 (13)	2-3/4 (70)	2 (51)
2	1-1/8 (29)	1/2 (13)	4 (102)	3-1/4 (83)
3	1-1/8 (29)	1/2 (13)	5-1/4 (133)	4-1/2 (114)
4	1-1/8 (29)	1/2 (13)	6-1/2 (165)	5-3/4 (146)
5	1-1/8 (29)	1/2 (13)	7-3/4 (197)	7 (178)
6	1-1/8 (29)	1/2 (13)	9 (229)	8-1/4 (210)
7	1-1/8 (29)	1/2 (13)	10-1/4 (260)	9-1/2 (241)
8	1-1/8 (29)	1/2 (13)	11-1/2 (292)	10-3/4 (273)

1975C (3/4" Spacing)				
SLOT	A	B	C	D
1	1-1/8 (29)	3/4 (19)	3 (76)	2-1/4 (57)
2	1-1/8 (29)	3/4 (19)	4-1/2 (114)	3-3/4 (95)
3	1-1/8 (29)	3/4 (19)	6 (152)	5-1/4 (133)
4	1-1/8 (29)	3/4 (19)	7-1/2 (191)	6-3/4 (171)
5	1-1/8 (29)	3/4 (19)	9 (229)	8-1/4 (210)
6	1-1/8 (29)	3/4 (19)	10-1/2 (267)	9-3/4 (248)
7	1-1/8 (29)	3/4 (19)	12 (305)	11-1/4 (286)
8	1-1/8 (29)	3/4 (19)	13-1/2 (343)	12-3/4 (324)

1910C (1" Spacing)				
SLOT	A	B	C	D
1	1-1/8 (29)	1 (25)	3-1/4 (83)	2-1/2 (64)
2	1-1/8 (29)	1 (25)	5 (127)	4-1/4 (108)
3	1-1/8 (29)	1 (25)	6-3/4 (171)	6 (152)
4	1-1/8 (29)	1 (25)	8-1/2 (216)	7-3/4 (197)
5	1-1/8 (29)	1 (25)	10-1/4 (260)	9-1/2 (241)
6	1-1/8 (29)	1 (25)	12 (305)	11-1/4 (286)
7	1-1/8 (29)	1 (25)	13-3/4 (349)	13 (330)
8	1-1/8 (29)	1 (25)	15-1/2 (394)	14-3/4 (375)

1915C (1-1/2" Spacing)				
SLOT	A	B	C	D
1	1-1/8 (29)	1-1/2 (38)	3-3/4 (95)	3 (76)
2	1-1/8 (29)	1-1/2 (38)	6 (152)	5-1/4 (133)
3	1-1/8 (29)	1-1/2 (38)	8-1/4 (210)	7-1/2 (191)
4	1-1/8 (29)	1-1/2 (38)	10-1/2 (267)	9-3/4 (248)

1920C (2" Spacing)				
SLOT	A	B	C	D
1	1-1/8 (29)	2 (51)	4-1/4 (108)	3-1/2 (89)
2	1-1/8 (29)	2 (51)	7 (178)	6-1/4 (159)
3	1-1/8 (29)	2 (51)	9-3/4 (248)	9 (229)
4	1-1/8 (29)	2 (51)	12-1/2 (318)	11-3/4 (298)

**NOTES :**

- Individual Sections Range from 12" (305) to 72" (1829) Long. Longer Units will Consist of Sections Butted Together with Alignment Pins
- See Form DS0710 for Length Details
- See Form DS0711 for 1900 Boot Information
- Construction is Extruded Aluminum with Steel Clips
- Standard Finish : Straight Frame - White, Blades - Back
- Standard Finish : Curved Frame - White, Deflectors - White

**OPTIONS :**

- STEEL BLANK OFF STRIPS
- NO BLADES

**DIMENSIONS GIVEN AS INCHES (MM)**

## 1900 SERIES LINEAR SLOT DIFFUSER

FRAME STYLE 'C'

SURFACE MOUNT WITH CONCEALED FASTENING

## SUBMITTAL SHEET

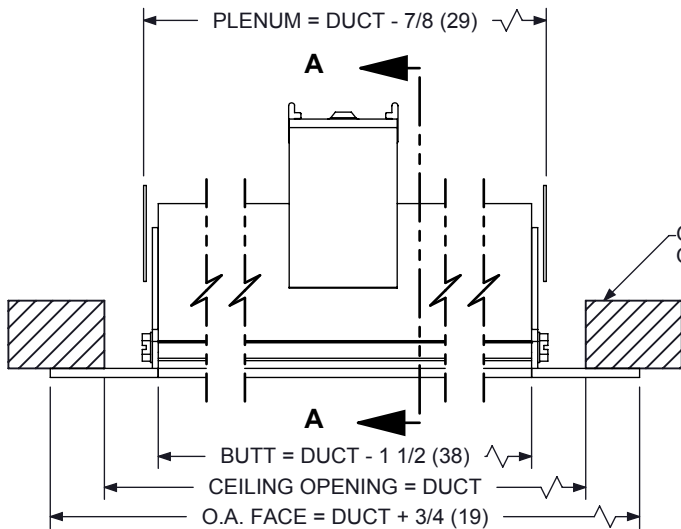

**SIDE VIEW**

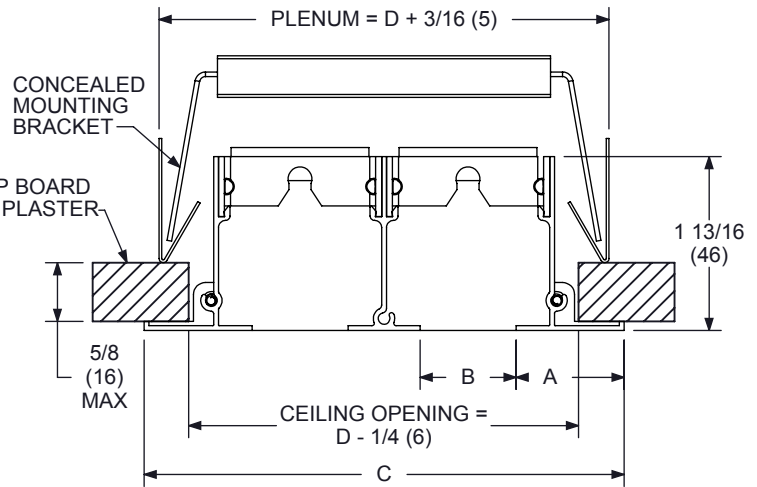

**SECTION A-A  
NO BLADES**

1950C (1/2" Spacing)				
SLOT	A	B	C	D
1	1-1/8 (29)	1/2 (13)	2-3/4 (70)	2 (51)
2	1-1/8 (29)	1/2 (13)	4 (102)	3-1/4 (83)
3	1-1/8 (29)	1/2 (13)	5-1/4 (133)	4-1/2 (114)
4	1-1/8 (29)	1/2 (13)	6-1/2 (165)	5-3/4 (146)
5	1-1/8 (29)	1/2 (13)	7-3/4 (197)	7 (178)
6	1-1/8 (29)	1/2 (13)	9 (229)	8-1/4 (210)
7	1-1/8 (29)	1/2 (13)	10-1/4 (260)	9-1/2 (241)
8	1-1/8 (29)	1/2 (13)	11-1/2 (292)	10-3/4 (273)

1975C (3/4" Spacing)				
SLOT	A	B	C	D
1	1-1/8 (29)	3/4 (19)	3 (76)	2-1/4 (57)
2	1-1/8 (29)	3/4 (19)	4-1/2 (114)	3-3/4 (95)
3	1-1/8 (29)	3/4 (19)	6 (152)	5-1/4 (133)
4	1-1/8 (29)	3/4 (19)	7-1/2 (191)	6-3/4 (171)
5	1-1/8 (29)	3/4 (19)	9 (229)	8-1/4 (210)
6	1-1/8 (29)	3/4 (19)	10-1/2 (267)	9-3/4 (248)
7	1-1/8 (29)	3/4 (19)	12 (305)	11-1/4 (286)
8	1-1/8 (29)	3/4 (19)	13-1/2 (343)	12-3/4 (324)

1910C (1" Spacing)				
SLOT	A	B	C	D
1	1-1/8 (29)	1 (25)	3-1/4 (83)	2-1/2 (64)
2	1-1/8 (29)	1 (25)	5 (127)	4-1/4 (108)
3	1-1/8 (29)	1 (25)	6-3/4 (171)	6 (152)
4	1-1/8 (29)	1 (25)	8-1/2 (216)	7-3/4 (197)
5	1-1/8 (29)	1 (25)	10-1/4 (260)	9-1/2 (241)
6	1-1/8 (29)	1 (25)	12 (305)	11-1/4 (286)
7	1-1/8 (29)	1 (25)	13-3/4 (349)	13 (330)
8	1-1/8 (29)	1 (25)	15-1/2 (394)	14-3/4 (375)

1915C (1-1/2" Spacing)				
SLOT	A	B	C	D
1	1-1/8 (29)	1-1/2 (38)	3-3/4 (95)	3 (76)
2	1-1/8 (29)	1-1/2 (38)	6 (152)	5-1/4 (133)
3	1-1/8 (29)	1-1/2 (38)	8-1/4 (210)	7-1/2 (191)
4	1-1/8 (29)	1-1/2 (38)	10-1/2 (267)	9-3/4 (248)

1920C (2" Spacing)				
SLOT	A	B	C	D
1	1-1/8 (29)	2 (51)	4-1/4 (108)	3-1/2 (89)
2	1-1/8 (29)	2 (51)	7 (178)	6-1/4 (159)
3	1-1/8 (29)	2 (51)	9-3/4 (248)	9 (229)
4	1-1/8 (29)	2 (51)	12-1/2 (318)	11-3/4 (298)

**NOTES :**

- Individual Sections Range from 12" (305) to 72" (1829) Long. Longer Units will Consist of Sections Butted Together with Alignment Pins
- See Form DS0710 for Length Details
- See Form DS0711 for 1900 Boot Information
- Construction is Extruded Aluminum with Steel Clips
- Standard Finish : Straight Frame - White, Blades - Back
- Standard Finish : Curved Frame - White, Deflectors - White

**OPTIONS :**

- STEEL BLANK OFF STRIPS
- WITH BLADES

**DIMENSIONS GIVEN AS INCHES (MM)**