

1900 SERIES LINEAR SLOT DIFFUSER FRAME STYLE 'J' SURFACE MOUNT, NO SCREW HOLES

JOB NAME _____
ENGINEER _____
CONTRACTOR _____
TAG _____

SUBMITTAL SHEET

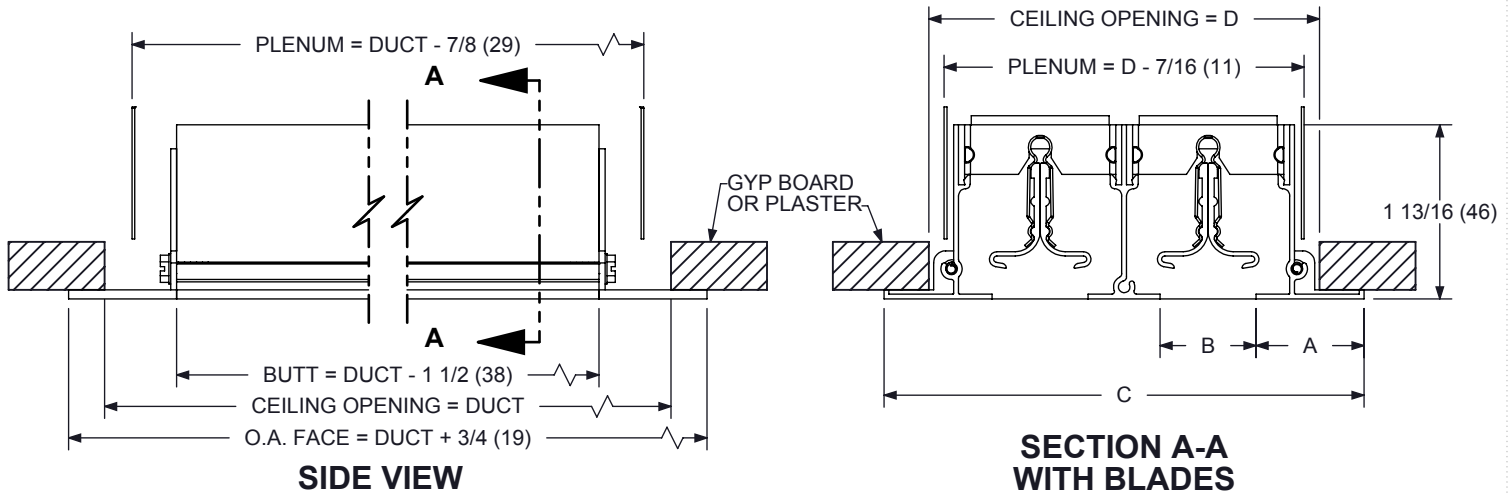

1950J (1/2" Spacing)				
SLOT	A	B	C	D
1	1-1/8 (29)	1/2 (13)	2-3/4 (70)	1-7/8 (48)
2	1-1/8 (29)	1/2 (13)	4 (102)	3-1/8 (79)
3	1-1/8 (29)	1/2 (13)	5-1/4 (133)	4-3/8 (111)
4	1-1/8 (29)	1/2 (13)	6-1/2 (165)	5-5/8 (143)
5	1-1/8 (29)	1/2 (13)	7-3/4 (197)	6-7/8 (175)
6	1-1/8 (29)	1/2 (13)	9 (229)	8-1/8 (206)
7	1-1/8 (29)	1/2 (13)	10-1/4 (260)	9-3/8 (238)
8	1-1/8 (29)	1/2 (13)	11-1/2 (292)	10-5/8 (270)

1975J (3/4" Spacing)				
SLOT	A	B	C	D
1	1-1/8 (29)	3/4 (19)	3 (76)	2-1/8 (54)
2	1-1/8 (29)	3/4 (19)	4-1/2 (114)	3-5/8 (92)
3	1-1/8 (29)	3/4 (19)	6 (152)	5-1/8 (130)
4	1-1/8 (29)	3/4 (19)	7-1/2 (191)	6-5/8 (168)
5	1-1/8 (29)	3/4 (19)	9 (229)	8-1/8 (206)
6	1-1/8 (29)	3/4 (19)	10-1/2 (267)	9-5/8 (244)
7	1-1/8 (29)	3/4 (19)	12 (305)	11-1/8 (283)
8	1-1/8 (29)	3/4 (19)	13-1/2 (343)	12-5/8 (321)

1910J (1" Spacing)				
SLOT	A	B	C	D
1	1-1/8 (29)	1 (25)	3-1/4 (83)	2-3/8 (60)
2	1-1/8 (29)	1 (25)	5 (127)	4-1/8 (105)
3	1-1/8 (29)	1 (25)	6-3/4 (171)	5-7/8 (149)
4	1-1/8 (29)	1 (25)	8-1/2 (216)	7-5/8 (194)
5	1-1/8 (29)	1 (25)	10-1/4 (260)	9-3/8 (238)
6	1-1/8 (29)	1 (25)	12 (305)	11-1/8 (283)
7	1-1/8 (29)	1 (25)	13-3/4 (349)	12-7/8 (327)
8	1-1/8 (29)	1 (25)	15-1/2 (394)	14-5/8 (371)

1915J (1-1/2" Spacing)				
SLOT	A	B	C	D
1	1-1/8 (29)	1-1/2 (38)	3-3/4 (95)	2-7/8 (73)
2	1-1/8 (29)	1-1/2 (38)	6 (152)	5-1/8 (130)
3	1-1/8 (29)	1-1/2 (38)	8-1/4 (210)	7-3/8 (187)
4	1-1/8 (29)	1-1/2 (38)	10-1/2 (267)	9-5/8 (244)

1920J (2" Spacing)				
SLOT	A	B	C	D
1	1-1/8 (29)	2 (51)	4-1/4 (108)	3-3/8 (86)
2	1-1/8 (29)	2 (51)	7 (178)	6-1/8 (156)
3	1-1/8 (29)	2 (51)	9-3/4 (248)	8-7/8 (225)
4	1-1/8 (29)	2 (51)	12-1/2 (318)	11-5/8 (295)

NOTES :

- Individual Sections Range from 12" (305) to 72" (1829) Long. Longer Units will Consist of Sections Butted Together with Alignment Pins
- See Form DS0710 for Length Details
- See Form DS0711 for 1900 Boot Information
- Construction is Extruded Aluminum with Steel Clips
- Standard Finish : Straight Frame - White, Blades - Back
- Standard Finish : Curved Frame - White, Deflectors - White

OPTIONS :

- STEEL BLANK OFF STRIPS
- NO BLADES

**DIMENSIONS GIVEN AS
INCHES (MM)**

1900 SERIES LINEAR SLOT DIFFUSER FRAME STYLE 'J' SURFACE MOUNT, NO SCREW HOLES

JOB NAME _____
ENGINEER _____
CONTRACTOR _____
TAG _____

SUBMITTAL SHEET

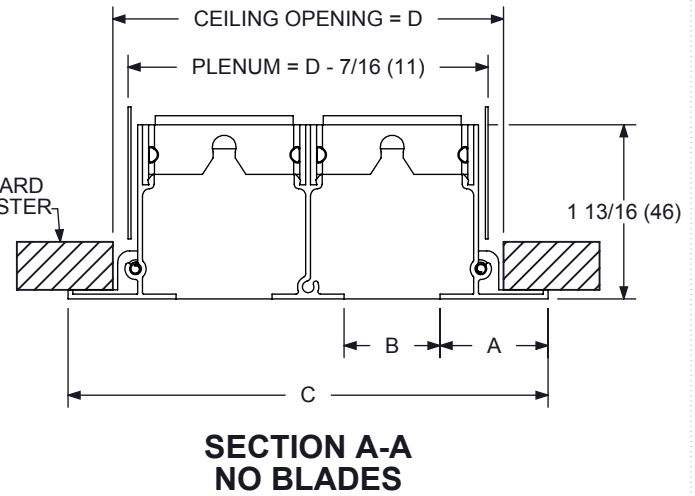
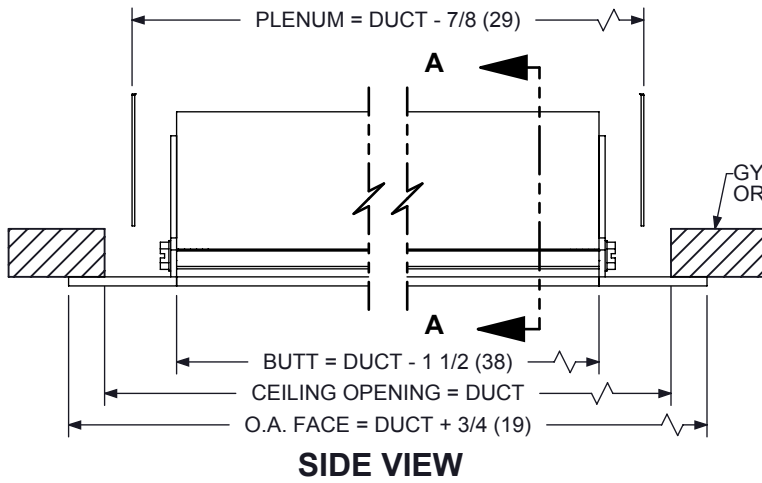

1950J (1/2" Spacing)				
SLOT	A	B	C	D
1	1-1/8 (29)	1/2 (13)	2-3/4 (70)	1-7/8 (48)
2	1-1/8 (29)	1/2 (13)	4 (102)	3-1/8 (79)
3	1-1/8 (29)	1/2 (13)	5-1/4 (133)	4-3/8 (111)
4	1-1/8 (29)	1/2 (13)	6-1/2 (165)	5-5/8 (143)
5	1-1/8 (29)	1/2 (13)	7-3/4 (197)	6-7/8 (175)
6	1-1/8 (29)	1/2 (13)	9 (229)	8-1/8 (206)
7	1-1/8 (29)	1/2 (13)	10-1/4 (260)	9-3/8 (238)
8	1-1/8 (29)	1/2 (13)	11-1/2 (292)	10-5/8 (270)

1975J (3/4" Spacing)				
SLOT	A	B	C	D
1	1-1/8 (29)	3/4 (19)	3 (76)	2-1/8 (54)
2	1-1/8 (29)	3/4 (19)	4-1/2 (114)	3-5/8 (92)
3	1-1/8 (29)	3/4 (19)	6 (152)	5-1/8 (130)
4	1-1/8 (29)	3/4 (19)	7-1/2 (191)	6-5/8 (168)
5	1-1/8 (29)	3/4 (19)	9 (229)	8-1/8 (206)
6	1-1/8 (29)	3/4 (19)	10-1/2 (267)	9-5/8 (244)
7	1-1/8 (29)	3/4 (19)	12 (305)	11-1/8 (283)
8	1-1/8 (29)	3/4 (19)	13-1/2 (343)	12-5/8 (321)

1910J (1" Spacing)				
SLOT	A	B	C	D
1	1-1/8 (29)	1 (25)	3-1/4 (83)	2-3/8 (60)
2	1-1/8 (29)	1 (25)	5 (127)	4-1/8 (105)
3	1-1/8 (29)	1 (25)	6-3/4 (171)	5-7/8 (149)
4	1-1/8 (29)	1 (25)	8-1/2 (216)	7-5/8 (194)
5	1-1/8 (29)	1 (25)	10-1/4 (260)	9-3/8 (238)
6	1-1/8 (29)	1 (25)	12 (305)	11-1/8 (283)
7	1-1/8 (29)	1 (25)	13-3/4 (349)	12-7/8 (327)
8	1-1/8 (29)	1 (25)	15-1/2 (394)	14-5/8 (371)

1915J (1-1/2" Spacing)				
SLOT	A	B	C	D
1	1-1/8 (29)	1-1/2 (38)	3-3/4 (95)	2-7/8 (73)
2	1-1/8 (29)	1-1/2 (38)	6 (152)	5-1/8 (130)
3	1-1/8 (29)	1-1/2 (38)	8-1/4 (210)	7-3/8 (187)
4	1-1/8 (29)	1-1/2 (38)	10-1/2 (267)	9-5/8 (244)

1920J (2" Spacing)				
SLOT	A	B	C	D
1	1-1/8 (29)	2 (51)	4-1/4 (108)	3-3/8 (86)
2	1-1/8 (29)	2 (51)	7 (178)	6-1/8 (156)
3	1-1/8 (29)	2 (51)	9-3/4 (248)	8-7/8 (225)
4	1-1/8 (29)	2 (51)	12-1/2 (318)	11-5/8 (295)

NOTES :

- Individual Sections Range from 12" (305) to 72" (1829) Long. Longer Units will Consist of Sections Butted Together with Alignment Pins
- See Form DS0710 for Length Details
- See Form DS0711 for 1900 Boot Information
- Construction is Extruded Aluminum with Steel Clips
- Standard Finish : Straight Frame - White, Blades - Back
- Standard Finish : Curved Frame - White, Deflectors - White

OPTIONS :

- STEEL BLANK OFF STRIPS
- WITH BLADES

**DIMENSIONS GIVEN AS
INCHES (MM)**