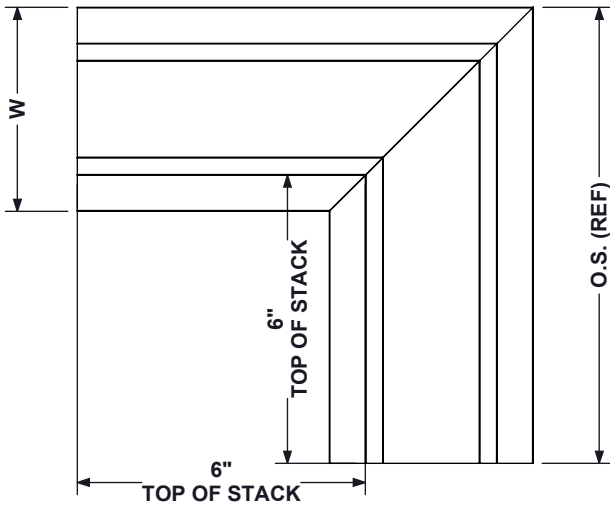

**DFMC**
**DESIGNFLO™ 90° ALUMINUM MITERED CORNER**
**SUBMITTAL SHEET**
 **DFMC**  
 90° MITERED CORNER

U.S. PATENT #6,220,958

**DFMC NOTES:**

- TRANSITIONS ARE INACTIVE WITH BLANK OFFS INSTALLED AT FACTORY
- SEE FORM GC0113 FOR DFMC135°
- SEE FORM GS0100 FOR ADDITIONAL DFL 1 SLOT DETAILS
- SEE FORM GS0102 FOR ADDITIONAL DFL 2 SLOT DETAILS
- 2 SLOT 'MC' UNITS ARE AVAILABLE IN 'NV' CONFIGURATION ONLY.

**OPTIONS:**

- FOR SPECIFIC ANGLES OTHER THAN 90° OR 135°. CONTACT KRUEGER SALES FOR DETAILS.

		<input type="checkbox"/> AA		<input type="checkbox"/> BB		<input type="checkbox"/> CC	
MODEL	SLOT	W	O.S.	W	O.S.	W	O.S.
<input type="checkbox"/> DFMC10	1 (25)	2 3/4 (70)	8 3/4 (222)	4 1/4 (108)	9 1/2 (241)	3 1/8 (79)	8 15/16 (227)
<input type="checkbox"/> DFMC15	1 1/2 (38)	3 3/4 (95)	9 3/4 (248)	5 1/4 (133)	10 1/2 (267)	4 1/8 (105)	9 15/16 (252)
<input type="checkbox"/> DFMC20	2 (51)	4 3/4 (121)	10 3/4 (273)	6 1/4 (159)	11 1/2 (292)	5 1/8 (130)	10 15/16 (278)
<input type="checkbox"/> DFMC25	2 1/2 (64)	5 3/4 (146)	11 3/4 (299)	6 3/4 (171)	12 1/4 (311)	6 1/8 (156)	11 15/16 (303)
<input type="checkbox"/> DFMC30	3 (76)	6 3/4 (171)	12 3/4 (324)	7 3/4 (197)	13 1/4 (337)	7 1/8 (181)	12 15/16 (329)
		<input type="checkbox"/> FF		<input type="checkbox"/> AD* / <input type="checkbox"/> DA*		<input type="checkbox"/> AC* / <input type="checkbox"/> CA**	
MODEL	SLOT	W	O.S.	W	O.S.	W	O.S.
<input type="checkbox"/> DFMC10	1 (25)	3 3/4 (95)	9 1/4 (235)	2 3/4 (70)	8 3/4 (222)	2 15/16 (75)	8 15/16 (227)
<input type="checkbox"/> DFMC15	1 1/2 (38)	4 3/4 (121)	10 1/4 (260)	3 3/4 (95)	9 3/4 (248)	3 15/16 (100)	9 15/16 (252)
<input type="checkbox"/> DFMC20	2 (51)	5 3/4 (146)	11 1/4 (286)	4 3/4 (121)	10 3/4 (273)	4 15/16 (125)	10 15/16 (278)
<input type="checkbox"/> DFMC25	2 1/2 (64)	6 3/4 (171)	12 1/4 (311)	NA	NA	5 15/16 (151)	11 15/16 (303)
<input type="checkbox"/> DFMC30	3 (76)	7 3/4 (197)	13 1/4 (337)	NA	NA	6 15/16 (176)	12 15/16 (329)

		FRAME STYLES					
		<input type="checkbox"/> AA		<input type="checkbox"/> BB		<input type="checkbox"/> CC	
MODEL	SLOT	W	O.S.	W	O.S.	W	O.S.
<input type="checkbox"/> DFMC10	1 (25)	5 3/16 (132)	11 3/16 (284)	6 11/16 (170)	11 15/16 (303)	5 9/16 (141)	11 3/8 (289)
<input type="checkbox"/> DFMC15	1 1/2 (38)	7 3/16 (183)	13 3/16 (335)	8 11/16 (221)	13 15/16 (354)	7 9/16 (192)	13 3/8 (340)
<input type="checkbox"/> DFMC20	2 (51)	9 3/16 (233)	15 3/16 (386)	10 11/16 (271)	15 15/16 (405)	9 9/16 (243)	15 3/8 (391)
<input type="checkbox"/> DFMC25	2 1/2 (64)	11 3/16 (284)	17 3/16 (437)	12 3/16 (310)	17 11/16 (450)	11 9/16 (294)	17 3/8 (445)
<input type="checkbox"/> DFMC30	3 (76)	13 3/16 (335)	19 3/16 (487)	14 3/16 (360)	19 11/16 (500)	13 9/16 (344)	19 3/8 (493)
		<input type="checkbox"/> FF		<input type="checkbox"/> AC*		<input type="checkbox"/> CA*	
MODEL	SLOT	W	O.S.	W	O.S.	W	O.S.
<input type="checkbox"/> DFMC10	1 (25)	7 3/16 (183)	11 11/16 (297)	5 3/8 (137)	11 3/8 (289)	5 3/8 (137)	11 3/16 (284)
<input type="checkbox"/> DFMC15	1 1/2 (38)	9 3/16 (233)	13 11/16 (348)	7 3/8 (187)	13 3/8 (340)	7 3/8 (187)	13 3/16 (335)
<input type="checkbox"/> DFMC20	2 (51)	11 3/16 (284)	15 11/16 (399)	9 3/8 (238)	15 3/8 (391)	9 3/8 (238)	15 3/16 (386)
<input type="checkbox"/> DFMC25	2 1/2 (64)	13 3/16 (335)	17 11/16 (450)	11 3/8 (289)	17 3/8 (445)	11 3/8 (289)	17 3/16 (437)
<input type="checkbox"/> DFMC30	3 (76)	15 3/16 (386)	19 11/16 (500)	13 3/8 (340)	19 3/8 (493)	13 3/8 (340)	19 3/16 (487)

\* THE FIRST FRAME LISTED WILL BE THE INSIDE EDGE FRAME

DIMENSIONS ARE GIVEN AS INCHES (MM)

\*\* FRAME CA "O.S." DIMENSIONS WILL MATCH FRAME AA O.S. DIMENSIONS