

JOB NAME _____
 ARCHITECT _____
 ENGINEER _____
 CONTRACTOR _____
 LOCATION _____

SUBMITTAL SHEET
 Form Number DS0356 Effective Date 8/00
 NEW

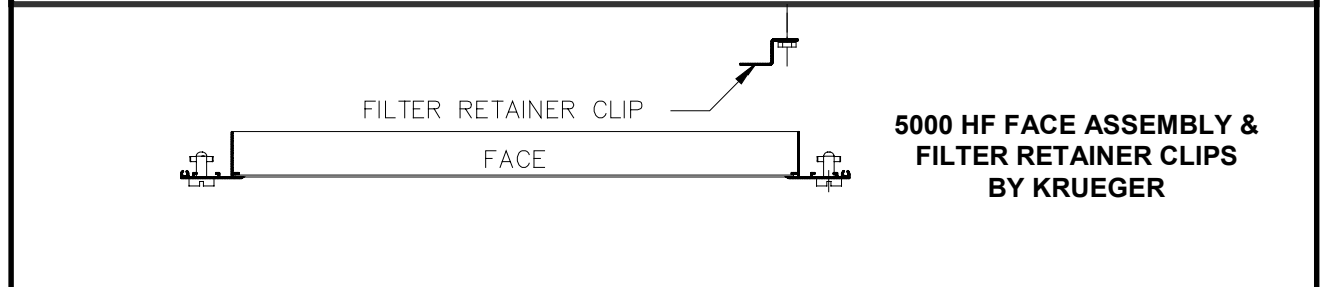

**5000HF SERIES
 GENERAL FILTER GUIDE LINES**

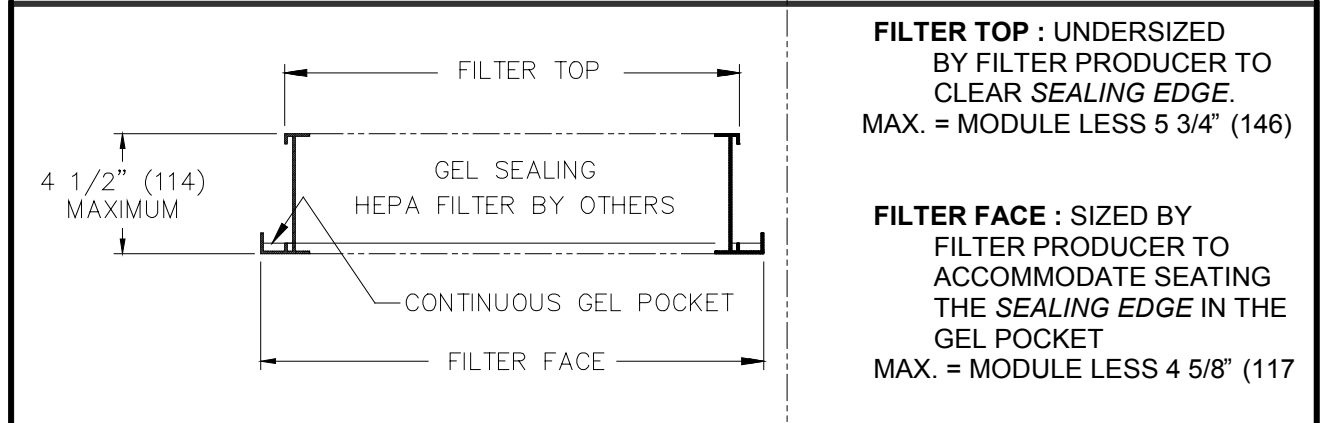
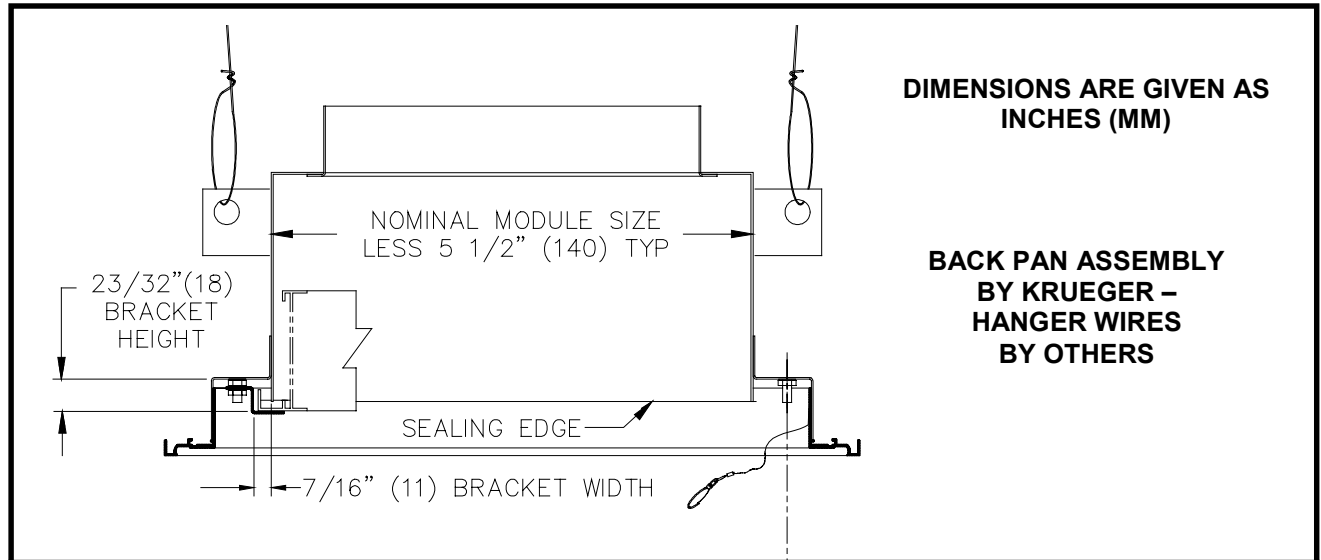

FILTER NOTE :
 ALL FILTERS ARE TO BE PROVIDED BY OTHERS BASED ON THE SPECIFICATIONS AS SHOWN ABOVE. ADDITIONAL DETAILS MAY BE FOUND ON FORM **DS0350** & INSTALLATION **DS0355**.