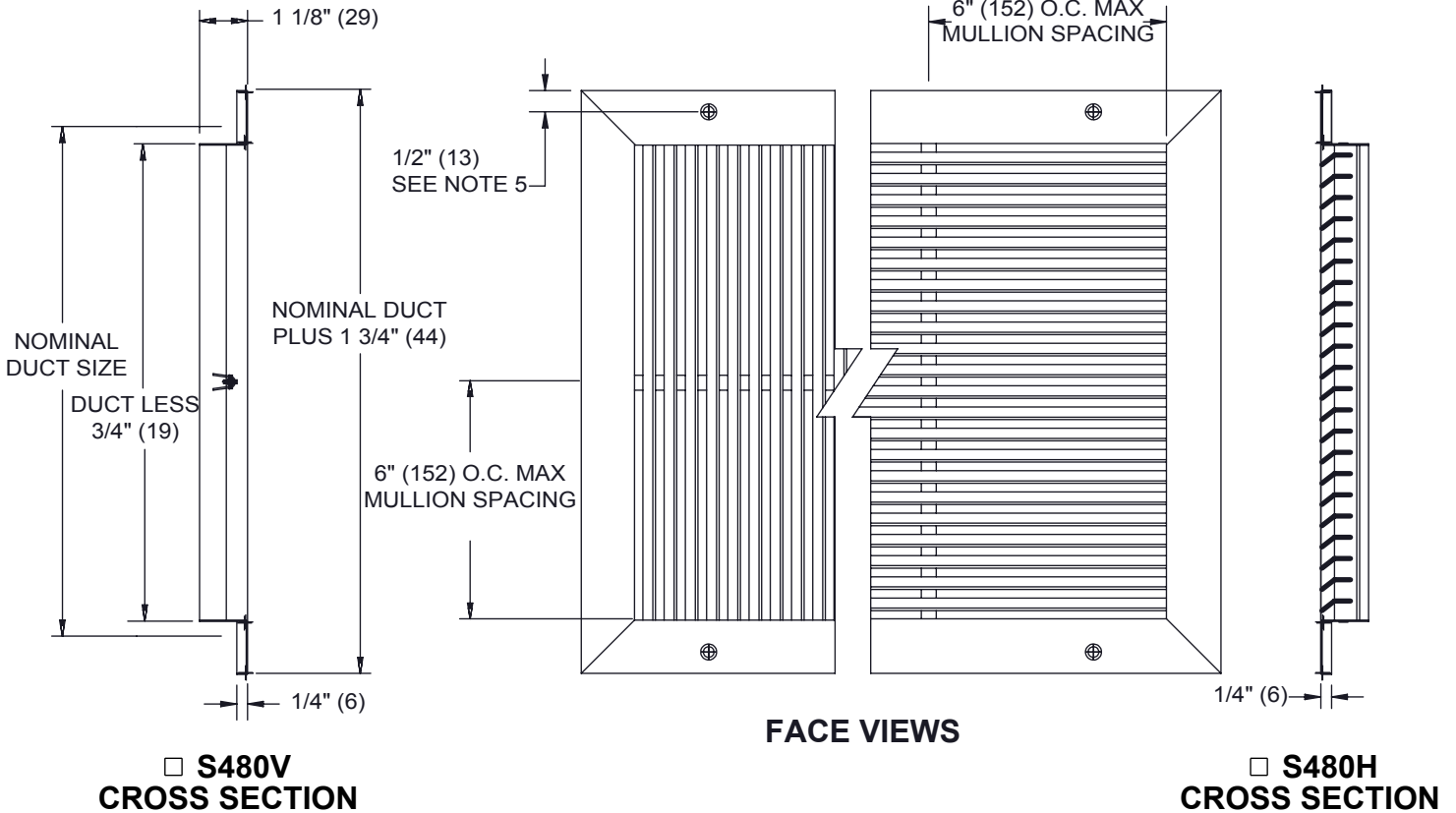
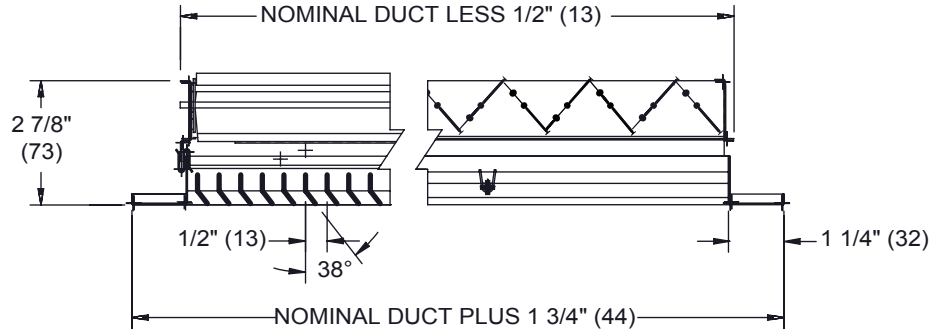

S480H, S480V SERIES
HEAVY DUTY 38° FIXED BLADE, SIDEWALL RETURN GRILLES SUBMITTAL SHEET

- S480V w/ OBD
- S480H w/ OBD

NOTES:

1. H OR V DESIGNATES 1. HORIZONTAL OR VERTICAL HEAVY DUTY BLADES FIXED ON 1/2" (13) CENTERS BY ROD AND MULLION SUPPORTS.
2. CONSTRUCTION IS STEEL: 16 GA FRAME, 14 GA BLADES.
3. OPTIONAL OBD SHIPS ATTACHED TO UNIT.
4. MAXIMUM SIZE OF A SINGLE CORE UNIT IS 48" x 48".
5. SCREW HOLE QUANTITY AND LOCATION WILL VARY WITH UNIT SIZE.

DIMENSIONS ARE GIVEN AS INCHES (MM)