

1500, 1600 ACCESSORIES

TYPICAL APPLICATIONS

SUBMITTAL SHEET

NOTE:

ALL OPTIONS WITH MOVEABLE PARTS ARE OPERATED THROUGH THE FACE OF THE UNIT.
 SERIES 1500, FRAME A, 4" NOMINAL WIDTH IS SHOWN UNLESS NOTED

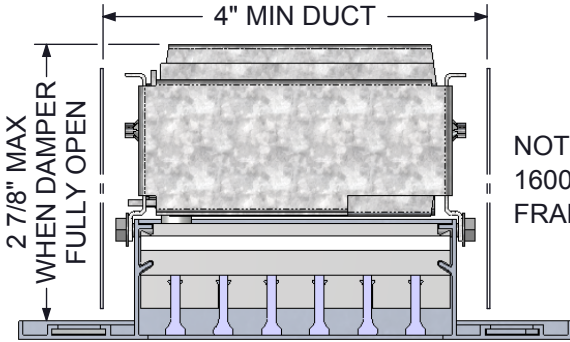

NOT COMPATIBLE WITH:
 1600 'N' SERIES UNITS
 FRAME STYLES DS & RG

- 01 STL OPPOSED BLADE DAMPER
- 02 AL

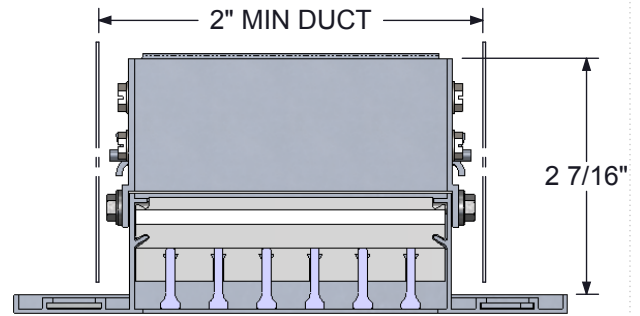

- L LINEAR STRAIGHTENING GRID

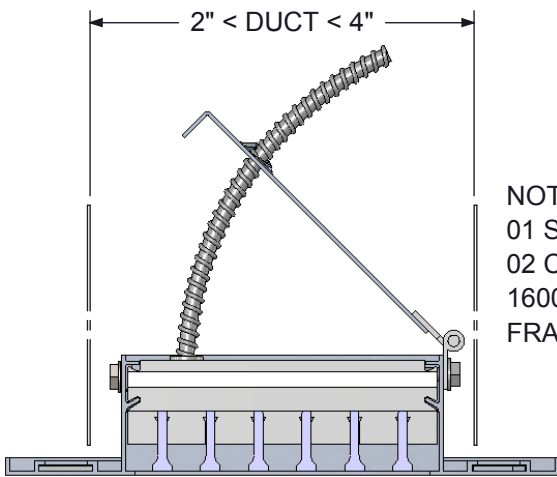

NOT COMPATIBLE WITH:
 01 SPRING CLIPS
 02 CONCEALED FASTENING
 1600 'N' SERIES UNITS
 FRAME STYLES DS & RG

- 19 STL SINGLE BLADE DAMPER
- 20 AL

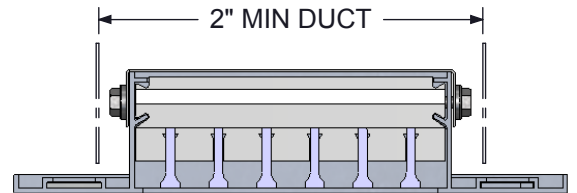

- B BLANK OFF STRIP

SHIPPED IN 6"-0" LENGTHS FOR
 FIELD CUTTING AND INSTALLATION.
 NOT COMPATIBLE WITH:
 01 SPRING CLIPS
 02 CONCEALED FASTENING

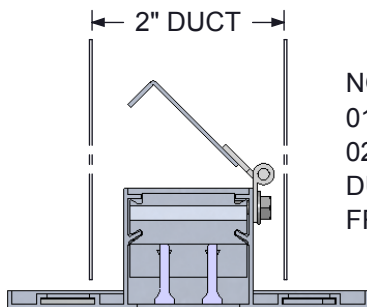

NOT COMPATIBLE WITH:
 01 SPRING CLIPS
 02 CONCEALED FASTENING
 DUCT WIDTH > 2"
 FRAME STYLES DS & RG

- 20 AL SINGLE BLADE DAMPER
 (FRICTION HINGE TYPE)