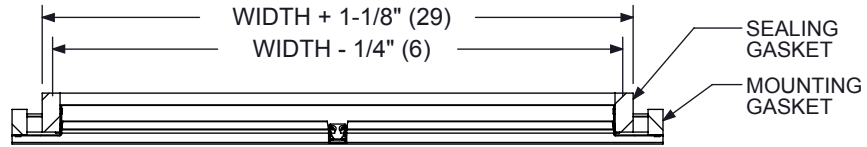
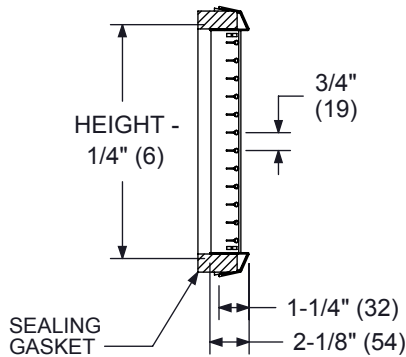
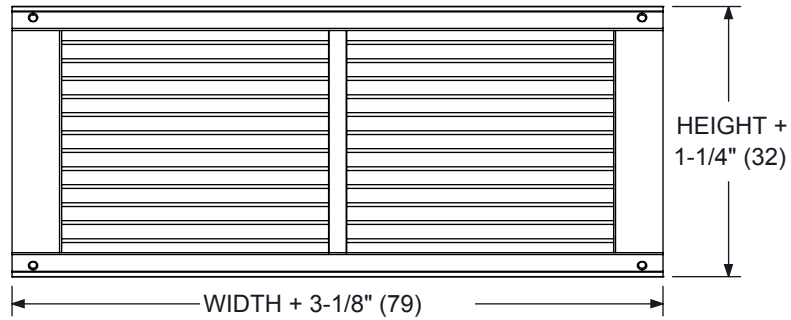
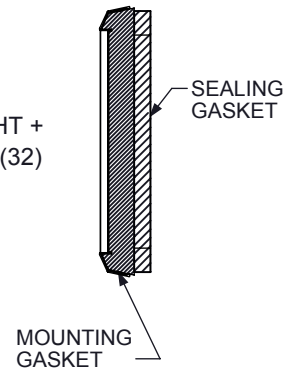
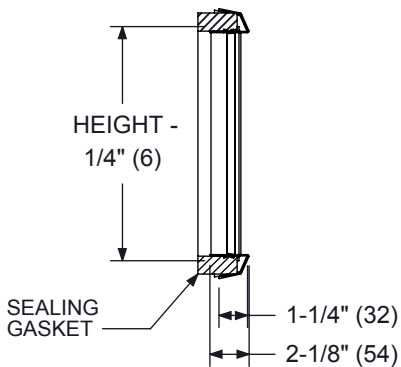
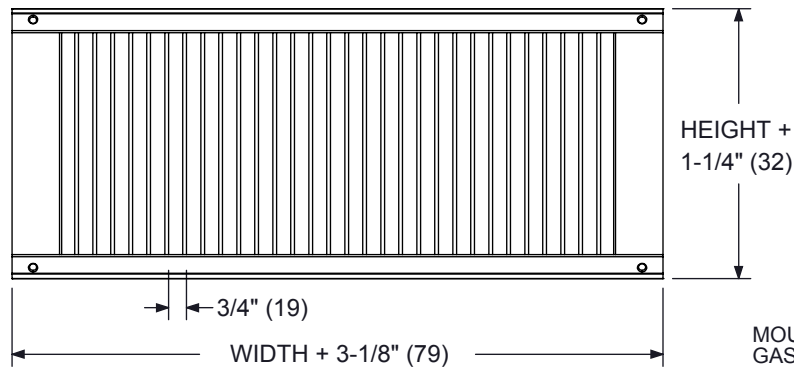
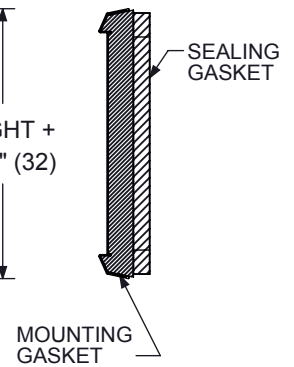

**5DMGSU**

 Single Deflection Universal Duct Mounted Grille - Aluminum Construction **SUBMITTAL SHEET**
**5DMGSUH TOP SECTION VIEW**

**SIDE SECTION VIEW**

**5DMGSUH FACE VIEW**

**SIDE VIEW**

 5DMGSUH

**SIDE SECTION VIEW**

**5DMGSUV FACE VIEW**

**SIDE VIEW**

 5DMGSUV

**NOTES:**

- ALL ALUMINUM CONSTRUCTION
- DESIGNATION: 5DMGDRH - HORIZONTAL FRONT DEFLECTORS, 5DMGDRV - VERTICAL FRONT DEFLECTORS
- STANDARD FINISH 44 WHITE OR 81 CLEAR ANODIZED.
- DIMENSIONS ARE INCHES (MM)
- DUCT DIAMETER AVAILABLE IN EVEN SIZES ONLY.
- 3/4" BLADE SPACING
- GASKET MATERIAL IS POLYURETHANE FOAM AND WILL COMPRESS WHEN INSTALLED
- HOLE OPENING IS EQUAL TO ORDERED WIDTH x HEIGHT

Height	3	4	6	8	10
Duct Diameter (Min / Max)	6 / 36	10 / 36	12 / 36	20 / 36	24 / 36
Width (Min / Max)	10 / 48		14 / 48		16 / 48

# 5DMGSU WITH DAMPER/EXTRACTOR

Single Deflection Universal Duct Mounted Grille - Aluminum Construction

# SUBMITTAL SHEET

With Damper/Extractor

5DMGSUH TOP SECTION VIEW

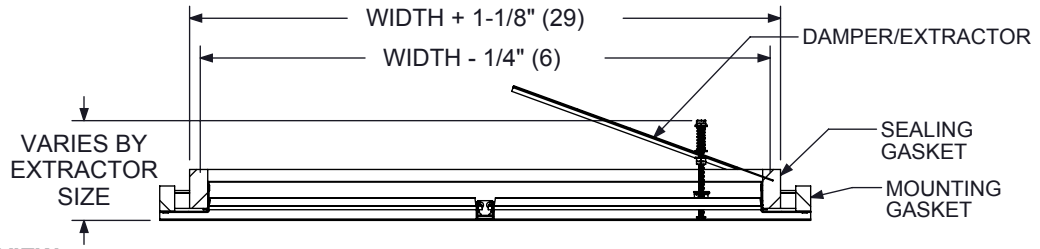

SIDE SECTION VIEW

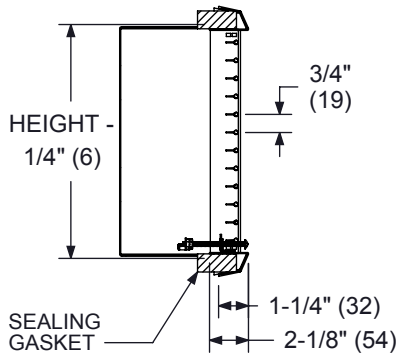

5DMGSUH FACE VIEW

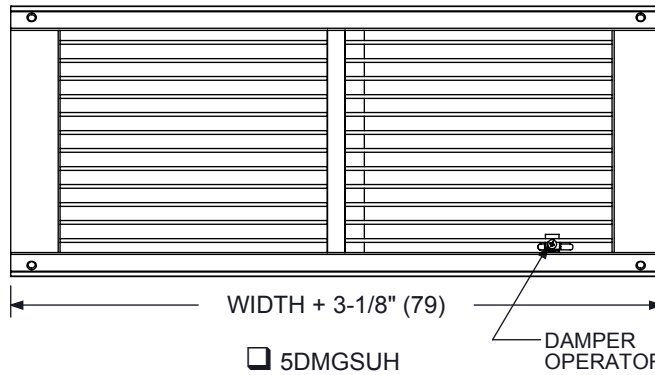

SIDE VIEW

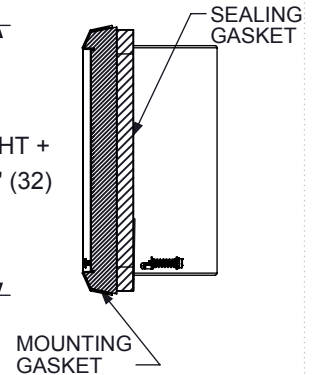

SIDE SECTION VIEW

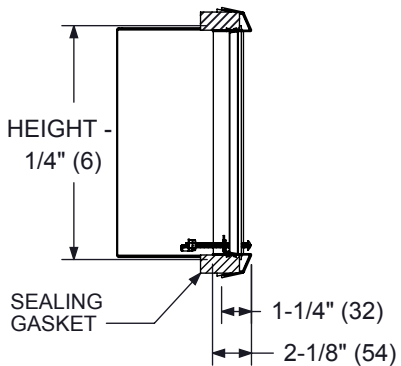

5DMGSUV FACE VIEW

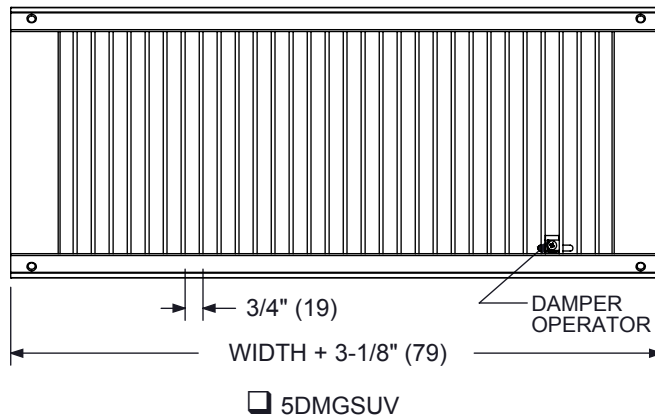

SIDE VIEW

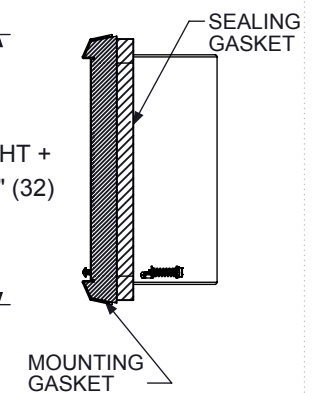

**NOTES:**

1. ALL ALUMINUM CONSTRUCTION
2. DESIGNATION: 5DMGDRH - HORIZONTAL FRONT DEFLECTORS, 5DMGDRV - VERTICAL FRONT DEFLECTORS
3. STANDARD FINISH 44 WHITE OR 81 CLEAR ANODIZED.
4. DIMENSIONS ARE INCHES (MM)
5. DUCT DIAMETER AVAILABLE IN EVEN SIZES ONLY.
6. 3/4" BLADE SPACING
7. GASKET MATERIAL IS POLYURETHANE FOAM AND WILL COMPRESS WHEN INSTALLED
8. HOLE OPENING IS EQUAL TO ORDERED WIDTH x HEIGHT

Height	3	4	6	8	10
Duct Diameter (Min / Max)	6 / 36	10 / 36	12 / 36	20 / 36	24 / 36
Width (Min / Max)	10 / 48		14 / 48		16 / 48