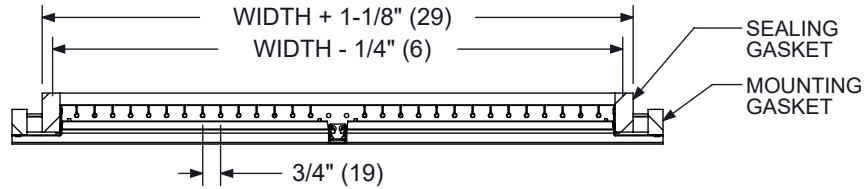
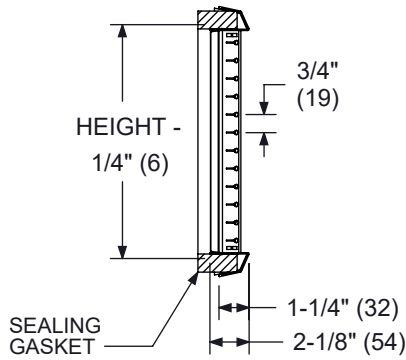
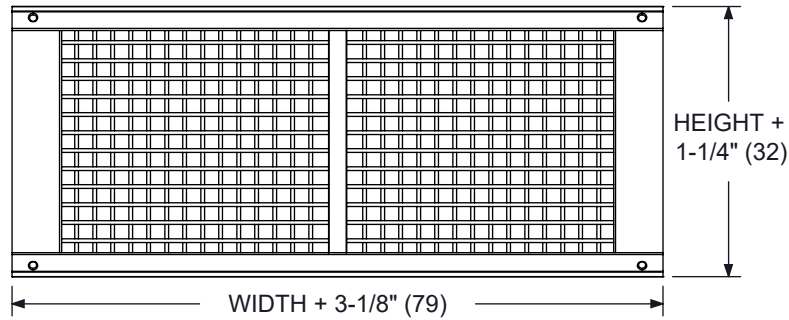
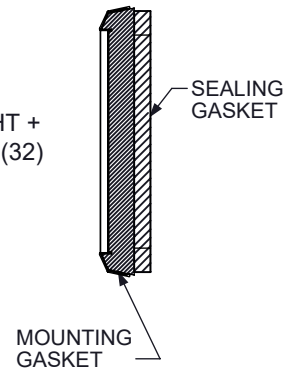
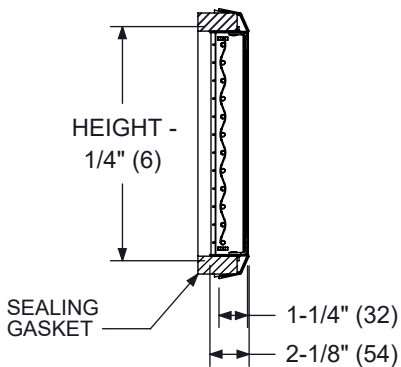
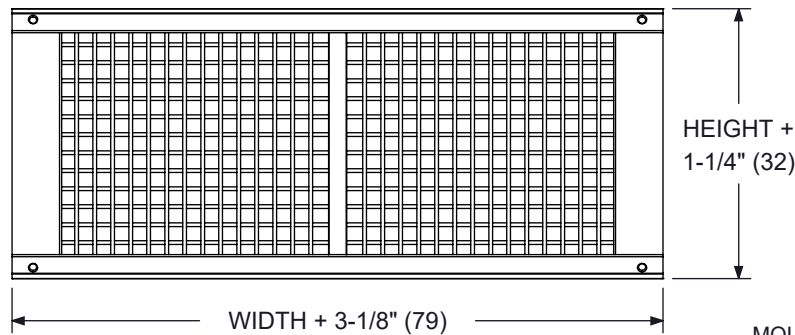
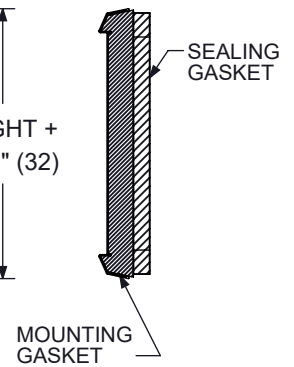

5DMGDU

Double Deflection Universal Duct Mounted Grille - Aluminum

SUBMITTAL SHEET
5DMGDUH TOP SECTION VIEW

SIDE SECTION VIEW

5DMGDUH FACE VIEW

SIDE VIEW

 5DMGDUH

SIDE SECTION VIEW

5DMGDUV FACE VIEW

SIDE VIEW

 5DMGDUV

NOTES:

1. ALL ALUMINUM CONSTRUCTION
2. DESIGNATION: 5DMGDRH - HORIZONTAL FRONT DEFLECTORS, 5DMGDRV - VERTICAL FRONT DEFLECTORS
3. STANDARD FINISH 44 WHITE OR 81 CLEAR ANODIZED.
4. DIMENSIONS ARE INCHES (MM)
5. DUCT DIAMETER AVAILABLE IN EVEN SIZES ONLY.
6. 3/4" BLADE SPACING
7. GASKET MATERIAL IS POLYURETHANE FOAM AND WILL COMPRESS WHEN INSTALLED
8. HOLE OPENING IS EQUAL TO ORDERED WIDTH x HEIGHT

Height	3	4	6	8	10
Duct Diameter (Min / Max)	6 / 36	10 / 36	12 / 36	20 / 36	24 / 36
Width (Min / Max)	10 / 48		14 / 48		16 / 48

5DMGDU WITH DAMPER/EXTRACTOR

Double Deflection Universal Duct Mounted Grille - Aluminum

SUBMITTAL SHEET

With Damper/Extractor

5DMGDUH TOP SECTION VIEW

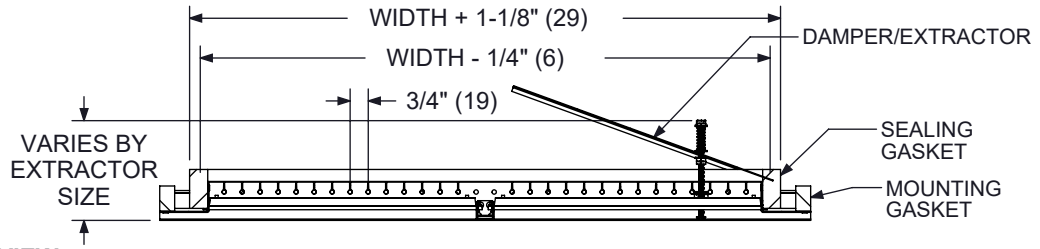

SIDE SECTION VIEW

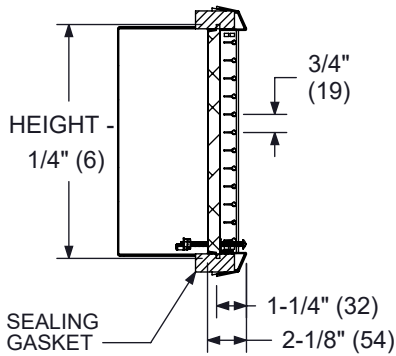

5DMGDUH FACE VIEW

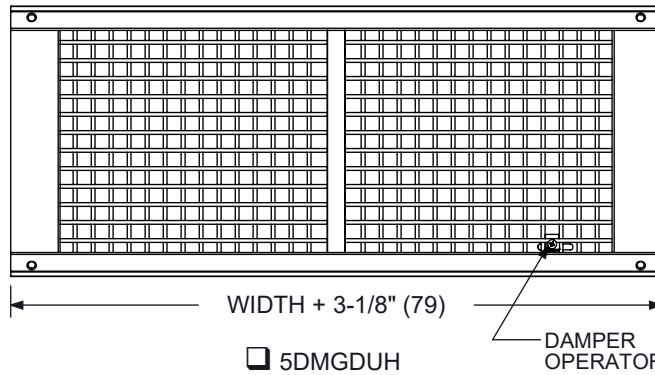

SIDE VIEW

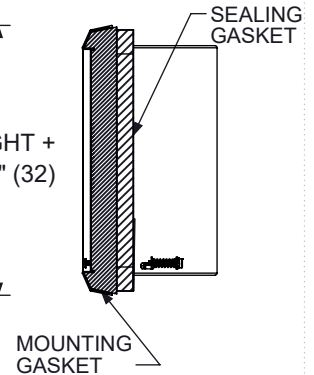

SIDE SECTION VIEW

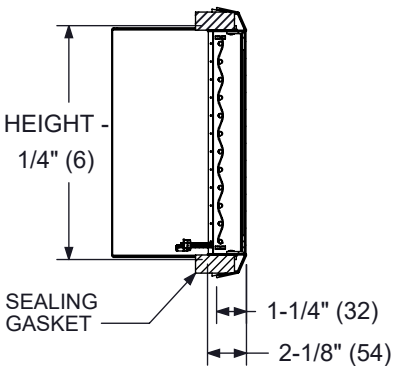

5DMGDUV FACE VIEW

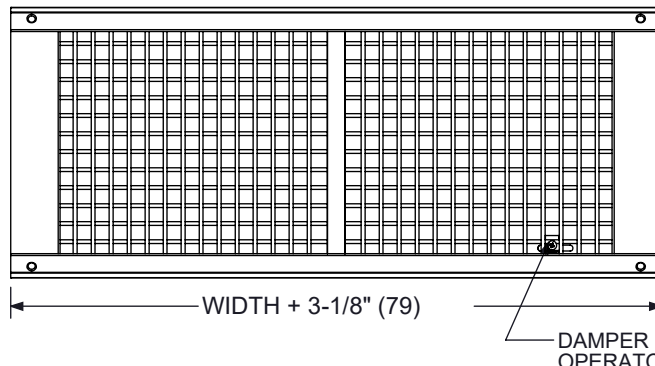

SIDE VIEW

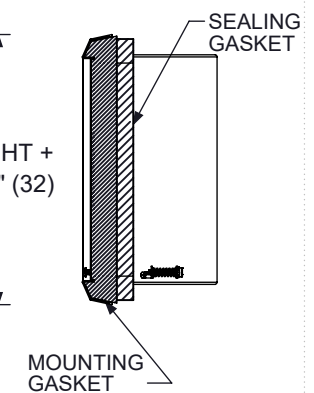

NOTES:

1. ALL ALUMINUM CONSTRUCTION
2. DESIGNATION: 5DMGDRH - HORIZONTAL FRONT DEFLECTORS, 5DMGDRV - VERTICAL FRONT DEFLECTORS
3. STANDARD FINISH 44 WHITE OR 81 CLEAR ANODIZED.
4. DIMENSIONS ARE INCHES (MM)
5. DUCT DIAMETER AVAILABLE IN EVEN SIZES ONLY.
6. 3/4" BLADE SPACING
7. GASKET MATERIAL IS POLYURETHANE FOAM AND WILL COMPRESS WHEN INSTALLED
8. HOLE OPENING IS EQUAL TO ORDERED WIDTH x HEIGHT

Height	3	4	6	8	10
Duct Diameter (Min / Max)	6 / 36	10 / 36	12 / 36	20 / 36	24 / 36
Width (Min / Max)	10 / 48		14 / 48		16 / 48