

Introduction: 1450 Series

The 1450 series are square face, 3-cone, round neck ceiling diffusers and are available in a variety of frame styles to help meet the architectural requirements of today's ceilings. The spacing of the inner cones in relation to the backpan result in a design possessing anti-smudge characteristics, preventing the buildup of particles on the ceiling, which is achieved by minimizing the low pressure region inherent to most 4-way directional blow diffusers. Also known as concentric cone diffusers, 1450s are constructed of one-piece stamped cones which provide a clean, smooth appearance without mitered corner joints. The 1450 series is an excellent variable air volume diffuser as represented in its throw characteristics at lower airflows; at typical flow rates, isothermal throws of 9-16 feet make this diffuser ideal for mounting centrally in many spaces while providing high mixing rates in the space.

MODELS

- 1450 - Steel Louvered Diffuser
- 51450 - Aluminum Louvered Diffuser (Safe for MRI use; F22 mounting hardware by others.)
- M1450 - Hard metric, Lay-in T-Bar Steel Louvered Diffuser
- M51450 - Hard metric, Lay-in T-Bar Aluminum Louvered Diffuser (Safe for MRI use; F22 mounting hardware by others.)

PANEL SIZES

- 12"x12", 20"x20", 24"x24", and 24"x48"
- 300x300mm and 600x600mm



1450

FEATURES

- Three cones for optimum airflow control.
- Great choice for variable air volume spaces.
- Cones feature a one-piece stamped construction without mitered joints.
- Round neck for easy connection to round duct.
- Anti-smudge design prevents smeared ceilings.
- Two earthquake tabs are standard.

ACCESSORIES

- Optional round damper.
- Optional insulated backpan (24"x24" only).

FINISHES

- Standard finish is #44 British White.
- Optional finishes available.

1450, 51450, M1450, M51450 Dimensional Information

1450, 51450, M1450, M51450, FACE VIEW

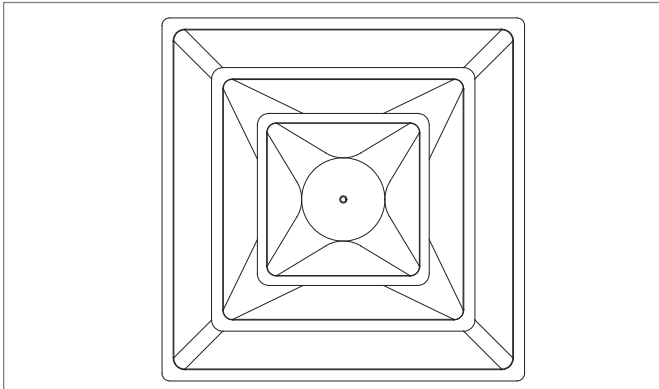

1450, 51450, M1450, M51450, CROSS SECTION

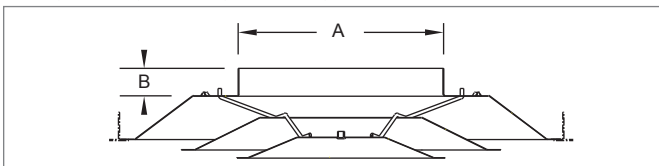

1450, 51450, M1450, M51450, 12"x12" & 300mm PANEL

Nominal Neck Size	Actual Neck Size	1450/M1450	51450/M51450
	A	B	B
06	5 7/8" (149)	1 1/4" (32)	1 1/2" (38)
08	7 7/8" (200)	1 1/4" (32)	1 1/2" (38)

1450, 51450, M1450, M51450, 24"x24" & 600mm PANEL

Nominal Neck Size	Actual Neck Size	1450/M1450	51450/M51450
	A	B	B
06	5 7/8" (149)	1 1/4" (32)	1 1/2" (38)
08	7 7/8" (200)	1 1/4" (32)	1 1/2" (38)
10	9 7/8" (251)	1 1/2" (38)	1 1/2" (38)
12	11 7/8" (302)	1 1/2" (38)	1 1/2" (38)
14	13 7/8" (352)	1 1/2" (38)	1 1/2" (38)
15	14 7/8" (378)	1 1/2" (38)	1 1/2" (38)

1450, 20"x20" PANEL

Nominal Neck Size	Actual Neck Size	1450/M1450	51450/M51450
	A	B	B
06	5 7/8" (149)	1" (25)	N/A
08	7 7/8" (200)		
08	9 7/8" (251)		

NOTE: Dimensions in parentheses are mm.

1450, 51450 Oversize Dimensional Information

1450, 51450, FRAME 12, LAY-IN T-BAR, 24"x24" PANEL

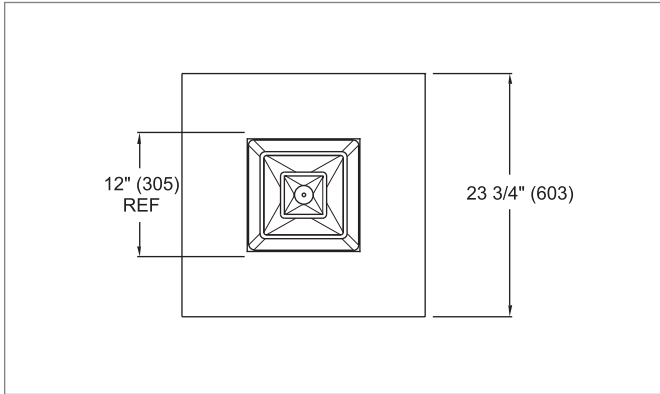

1450, 51450, FRAME 23, LAY-IN T-BAR, 24"x48" PANEL

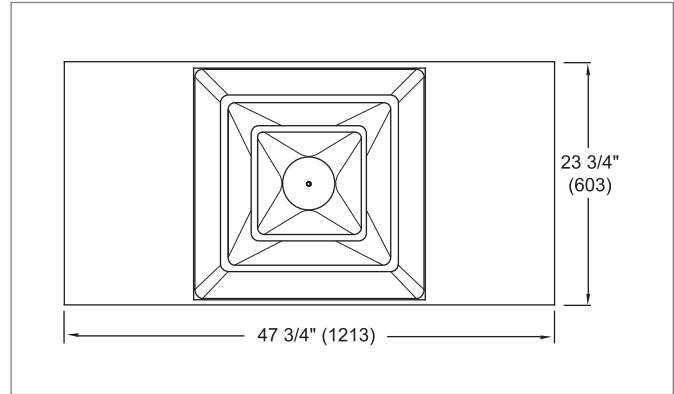

LOUVERED FACE DIFFUSERS

1450, 51450, CROSS SECTION, LAY-IN T-BAR, 24"x24" & 24"x48" PANEL

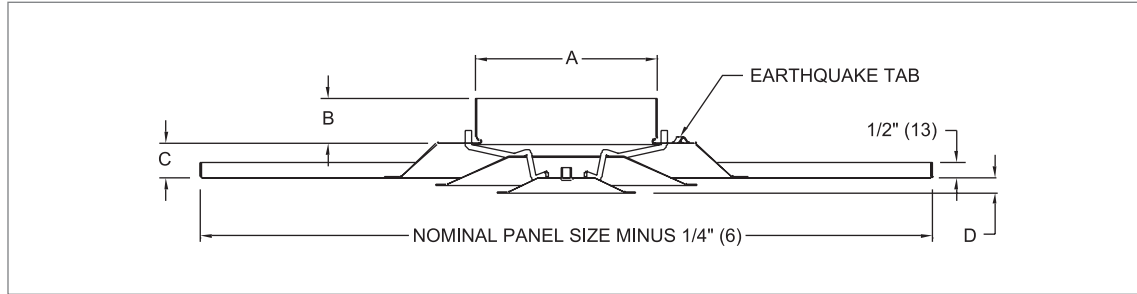

1450, 51450, FRAME 12, LAY-IN T-BAR, 24"x24" PANEL, OVERSIZE

Nominal Neck Size	Actual Neck Size	1450 Frame 12				51450 Frame 12		
		A	B	C	D	B	C	D
06	5 7/8" (149)	1 1/4" (32)	1 1/8" (29)	11/16" (17)	1 1/2" (38)	1 1/8" (29)	11/16" (17)	
08	7 7/8" (200)	1 1/4" (32)	1 1/8" (29)	11/16" (17)	1 1/2" (38)	1 1/8" (29)	11/16" (17)	

1450, 51450, FRAME 23, LAY-IN T-BAR, 24"x48" PANEL, OVERSIZE

Nominal Neck Size	Actual Neck Size	1450 Frame 23				51450 Frame 23		
		A	B	C	D	B	C	D
06	5 7/8" (149)	1 1/4" (32)	2 3/8" (60)	7/8" (22)	1 1/2" (38)	2 3/8" (60)	7/8" (22)	
08	7 7/8" (200)	1 1/4" (32)	2 3/8" (60)	7/8" (22)	1 1/2" (38)	2 3/8" (60)	7/8" (22)	
10	9 7/8" (251)	1 1/2" (38)	2 3/8" (60)	7/8" (22)	1 1/2" (38)	2 3/8" (60)	7/8" (22)	
12	11 7/8" (302)	1 1/2" (38)	2 3/8" (60)	7/8" (22)	1 1/2" (38)	2 3/8" (60)	7/8" (22)	
14	13 7/8" (352)	1 1/2" (38)	2 3/8" (60)	7/8" (22)	1 1/2" (38)	2 3/8" (60)	7/8" (22)	
15	14 7/8" (378)	1 1/2" (38)	2 3/8" (60)	7/8" (22)	1 1/2" (38)	2 3/8" (60)	7/8" (22)	

NOTE: Dimensions in parentheses are mm.

1
4
5
0
-
5
1
4
5
0

1450, 51450, M1450, M51450 Frame Styles

FRAME 22, SURFACE MOUNT, 12"x12" PANEL

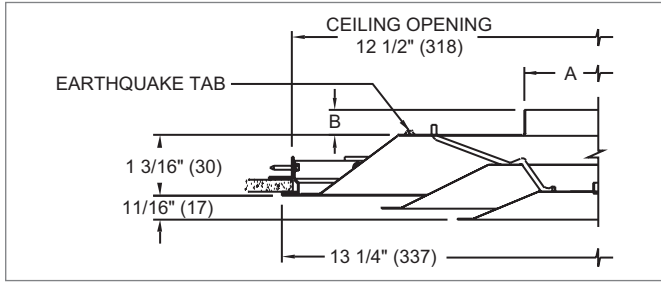

FRAME 22, SURFACE MOUNT, 24"x24" PANEL

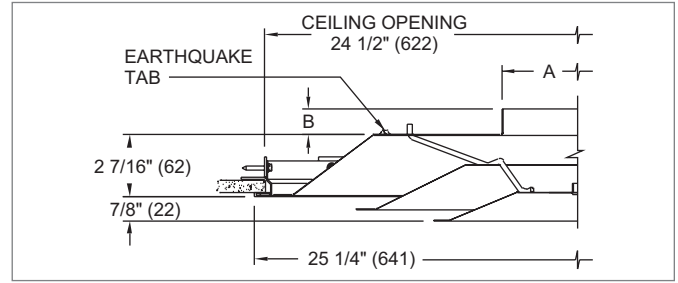

FRAME 23, LAY-IN T-BAR, 12"x12" & 20"x20" PANEL

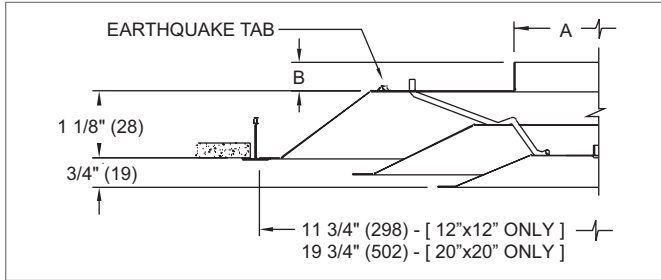

FRAME 23, LAY-IN T-BAR, 24"x24" PANEL

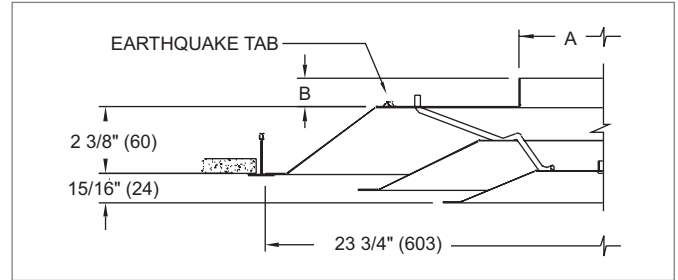

FRAME 27, SPLINE, 12"x12" PANEL

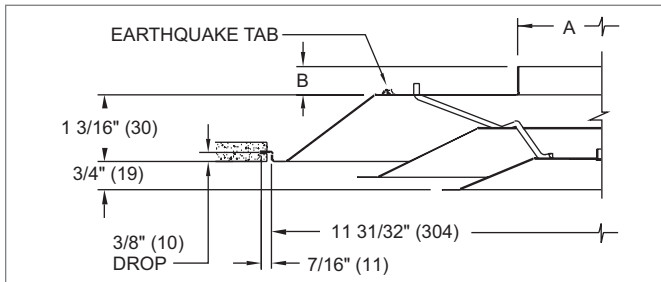

FRAME 27, SPLINE, 24"x24" PANEL

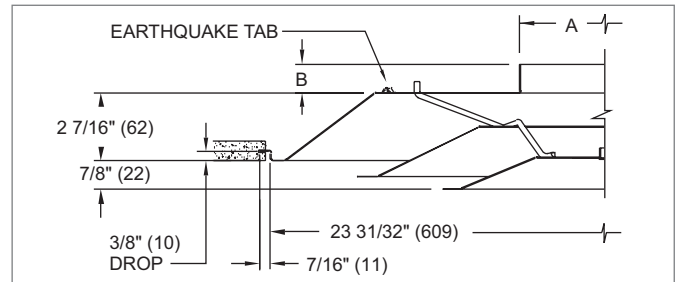

FRAME 98, NARROW-T, 12"x12" PANEL

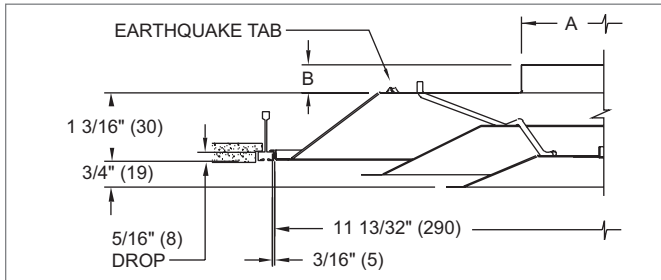

FRAME 98, NARROW-T, 24"x24" PANEL

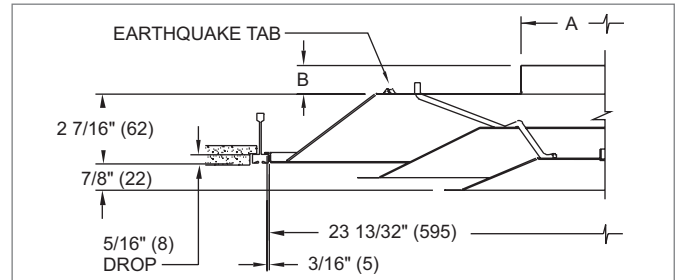

FRAME 23, LAY-IN T-BAR, (300x300) METRIC

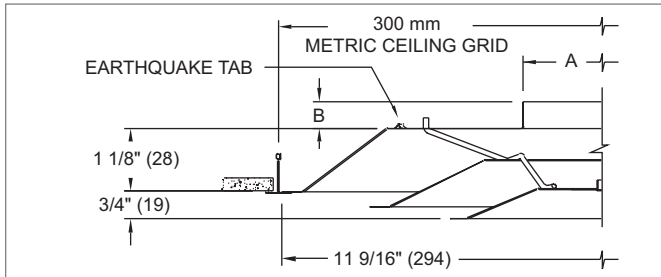

FRAME 23, LAY-IN T-BAR, (600x600) METRIC

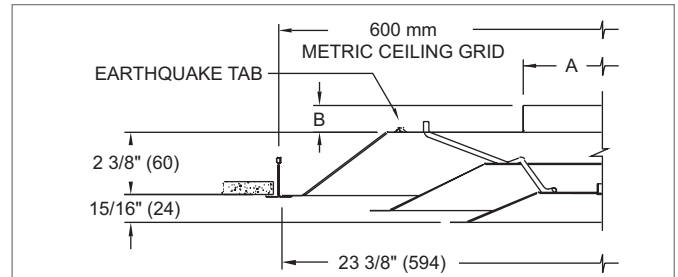

NOTES: Dimensions in parentheses are mm. For 'A' & 'B' dimensions, see page B1-23. Frame 22 includes separate surface mounting frame, as shown in the frame details above.