

## DIMENSIONAL DATA | 1190, 51190 (RETURN)

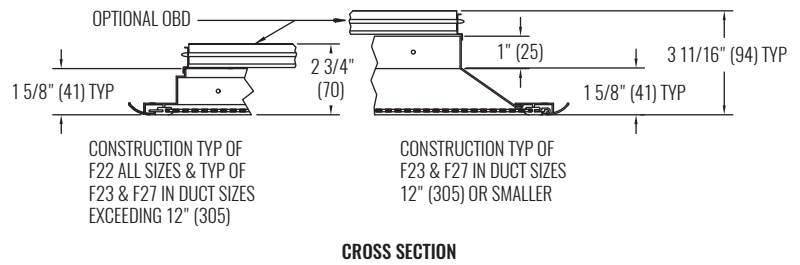
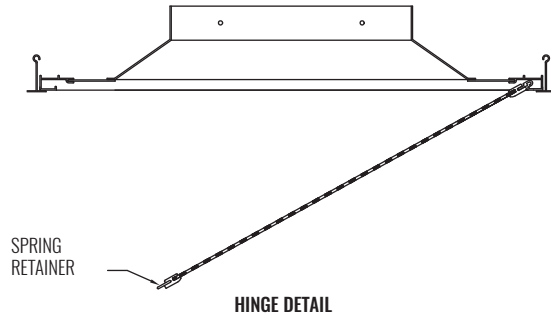
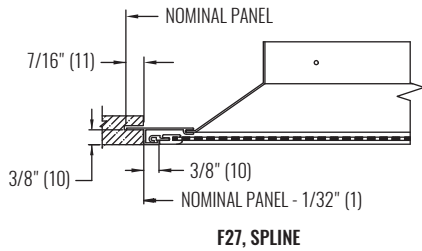
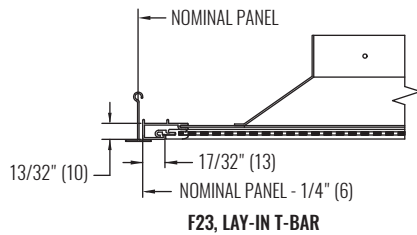
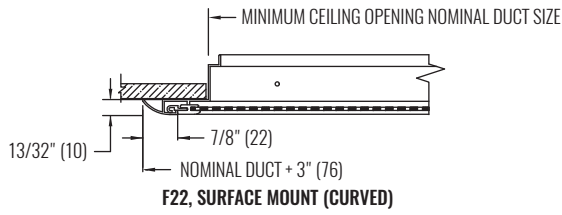

AVAILABLE SIZES									
NECK SIZE	F22, SURFACE MOUNT	FRAME 23, STANDARD T-BAR				FRAME 27, SPLINE, NARROW-T			
		12"x12" (305x305)	12"x24" (305x610)	24"x24" (610x610)	24"x48" (610x1219)	12"x12" (305x305)	12"x24" (305x610)	24"x24" (610x610)	24"x48" (610x1219)
6" x 6" (152 x 152)	•	•	•	•		•	•	•	
8" x 8" (203 x 203)	•			•				•	
10" x 10" (254 x 254)	•	•		•		•		•	
12" x 12" (305 x 305)	•			•				•	
14" x 14" (356 x 356)	•			•				•	
16" x 16" (406 x 406)	•			•				•	
18" x 18" (457 x 457)	•			•				•	
20" x 20" (508 x 508)	•			•				•	
10" x 22" (254 x 559)	•		•	•				•	
22" x 22" (559 x 559)	•			•				•	
12" x 24" (305 x 610)	•								
24" x 24" (610 x 610)	•								
22" x 46" (559 x 1168)	•				•				•

NOTES: Dimensions in parentheses are mm. Dot indicates available neck size.