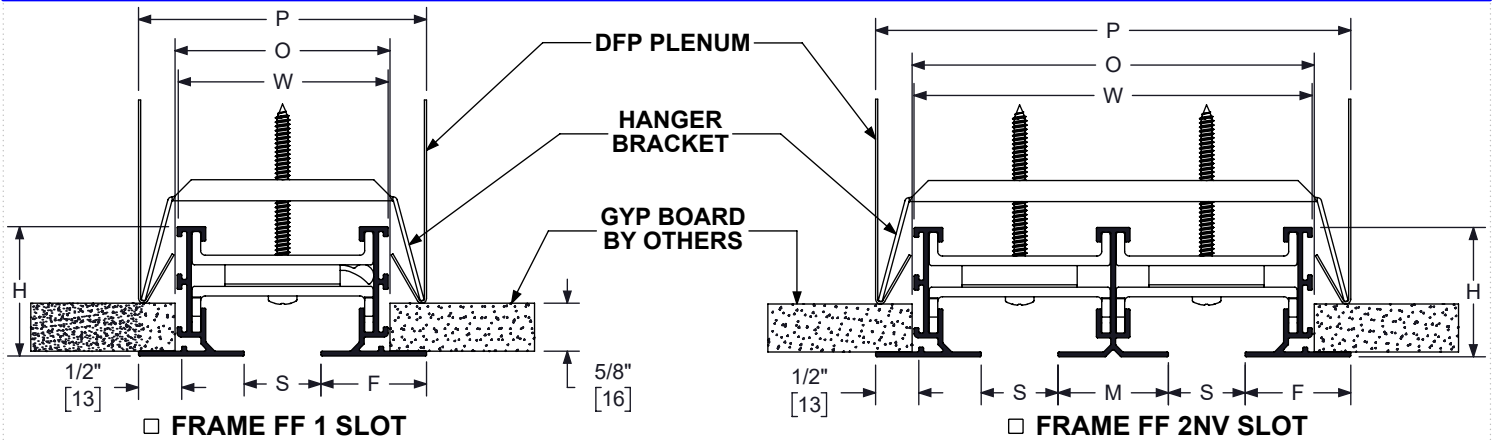

DESIGNFLO™ / DFP
DFL FRAME FF WITH CONCEALED MOUNTING OPTIONS
SUBMITTAL SHEET

DFL NOTES:

- CONSTRUCTION IS EXTRUDED ALUMINUM WITH ENGINEERED POLYMER COMPONENTS
- SEE FORM GS0100 FOR ADDITIONAL DFL 1 SLOT DETAILS
- SEE FORM GS0102 FOR ADDITIONAL DFL 2 SLOT DETAILS

ACCESSORY OPTIONS:

- HT - HORIZONTAL AIR FLOW
- VT - VERTICAL AIR FLOW
- 00 - NO BLADES

MODEL	SLOT S	FRAME F	HEIGHT H	ONE SLOT			TWO SLOT			
				STACK W	OPENING O	PLENUM P	STACK W	OPENING O	PLENUM P	FRAME M
<input type="checkbox"/> DFL10	1 [25]	1 3/8 [35]	1 11/16 [43]	2 3/4 [70]	3 [76]	3 3/4 [95]	5 3/16 [132]	5 1/2 [140]	6 3/16 [157]	1 7/16 [37]
<input type="checkbox"/> DFL15	1 1/2 [38]	1 5/8 [41]	1 11/16 [43]	3 3/4 [95]	4 [102]	4 3/4 [121]	7 3/16 [183]	7 1/2 [191]	8 3/16 [208]	1 15/16 [49]
<input type="checkbox"/> DFL20	2 [51]	1 7/8 [48]	1 11/16 [43]	4 3/4 [121]	5 [127]	5 3/4 [146]	9 3/16 [233]	9 1/2 [241]	10 3/16 [258]	2 7/16 [62]
<input type="checkbox"/> DFL25	2 1/2 [64]	2 1/8 [54]	2 5/16 [59]	5 3/4 [146]	6 [152]	6 3/4 [171]	11 3/16 [284]	11 1/2 [292]	12 3/16 [310]	2 15/16 [75]
<input type="checkbox"/> DFL30	3 [76]	2 3/8 [60]	2 5/16 [59]	6 3/4 [171]	7 [178]	7 3/4 [197]	13 3/16 [335]	13 1/2 [343]	14 3/16 [360]	3 7/16 [87]

DFP MODELS :

- DFP PLENUM BOOT, TYPE F

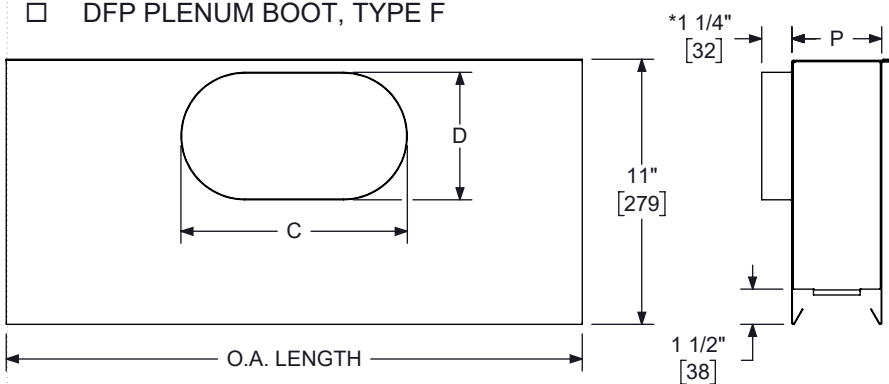
ACCESSORY OPTIONS:

- 1/4" [6], 2LB DENSITY FIBERGLASS INSULATION, ENDCAPS ARE NOT INSULATED
- 1/4" [6], CLOSED CELL FIBER FREE INSULATION, ENDCAPS ARE NOT INSULATED
- QUADRANT DAMPER - ADDS 6" [152] TO INLET DEPTH. SEE FORM GC0114

INLET SIZE	C	D
<input type="checkbox"/> 6" OVAL	6 1/4 [159]	5 1/4 [133]
<input type="checkbox"/> 8" OVAL	9 3/8 [238]	5 1/4 [133]
<input type="checkbox"/> 10" OVAL	12 1/2 [318]	5 1/4 [133]
<input type="checkbox"/> 12" OVAL	14 1/8 [359]	7 7/8 [200]

DIMENSIONS ARE GIVEN AS INCHES [MM]

MODEL	NOMINAL LENGTH	O.A. LENGTH	ONE SLOT	TWO NV SLOT
			PLENUM WIDTH P	PLENUM WIDTH P
<input type="checkbox"/> DFP 10	24 [610]	24 [610]	3 3/4 [95]	6 3/16 [157]
<input type="checkbox"/> DFP 15	36 [914]	36 [914]	4 3/4 [121]	8 3/16 [208]
<input type="checkbox"/> DFP 20	48 [1219]	48 [1219]	5 3/4 [146]	10 3/16 [258]
<input type="checkbox"/> DFP 25	60 [1524]	60 [1524]	6 3/4 [171]	12 3/16 [310]
<input type="checkbox"/> DFP 30	72 [1829]	72 [1829]	7 3/4 [197]	14 3/16 [360]