

JOB NAME _____
 ARCHITECT _____
 ENGINEER _____
 CONTRACTOR _____
 LOCATION _____

SUBMITTAL SHEET
 Form Number GS0075.1 Effective Date 01/06
 Replaces GS0075



RPN2P / RPN4P – ROUND PUNKAH NOZZLE
PANEL MOUNTED NOZZLES

RPN2P

RPN2P
w/APERTURE
DAMPER

RPN4P

RPN4P
w/APERTURE
DAMPER

ALUMINUM PANEL

STAINLESS STEEL PANEL

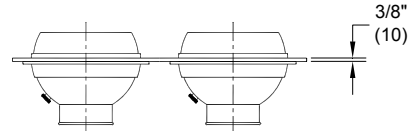
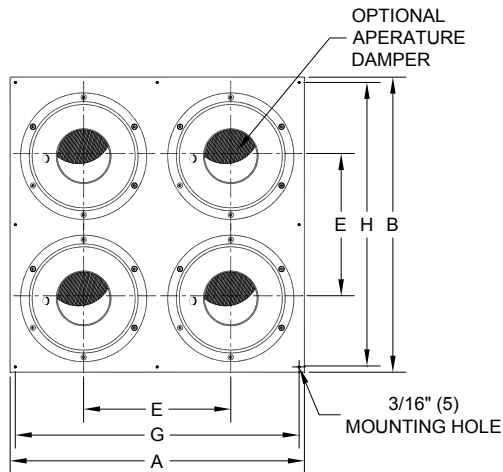
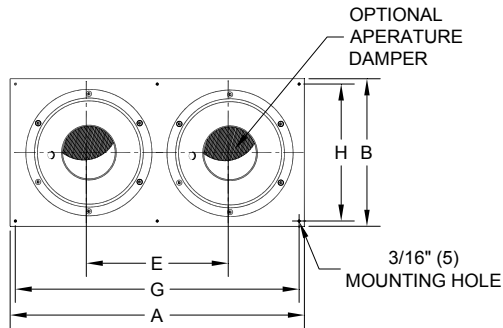

STANDARD FEATURES:

1. Easy Finger Tip Adjustment.
2. Directional Air Pattern Control
70° Global Rotation Minimum.
± 35° Deflection
360° Rotation
3. Heavy Gage Aluminum Construction.
4. Stainless Steel Damper Hardware.
5. Foam Gasketing Seals Nozzles in Panel
6. All units include Mounting Screws for surface mounted application.
7. Aperture Damper must be ordered with the unit, it cannot be field installed.
8. Standard Finish is 44 White.
9. Other finishes are available.

NOMINAL DUCT SIZE	RPN PER PANEL	A	B	E	G	H
16" x 8" (406 x 203)	2 - 6" (152)	18" (457)	10" (254)	9 1/2" (241)	17" (432)	9" (229)
22" x 10" (559 x 254)	2 - 8" (203)	24" (610)	12" (305)	11 1/2" (292)	23" (584)	11" (279)
26" x 12" (660 x 305)	2 - 10" (254)	28" (711)	14" (356)	13 1/2" (343)	27" (686)	13" (330)
30" x 14" (762 x 356)	2 - 12" (305)	32" (813)	16" (406)	15 1/2" (394)	31" (787)	15" (381)
16" x 16" (406 x 406)	4 - 6" (152)	18" (457)	18" (457)	9 1/2" (241)	17" (432)	17" (432)
22" x 22" (559 x 559)	4 - 8" (203)	24" (610)	24" (610)	11 1/2" (292)	23" (584)	23" (584)
26" x 26" (660 x 660)	4 - 10" (254)	28" (711)	28" (711)	13 1/2" (343)	27" (686)	27" (686)
30" x 30" (762 x 762)	4 - 12" (305)	32" (813)	32" (813)	15 1/2" (394)	31" (787)	31" (787)

**DIMENSIONS
ARE GIVEN AS
INCHES (MM)**

NOTE: DIMENSIONS ROUNDED TO THE NEAREST 1/16" (2)