

## LMHS EXHAUST UNIT

## SUBMITTAL SHEET

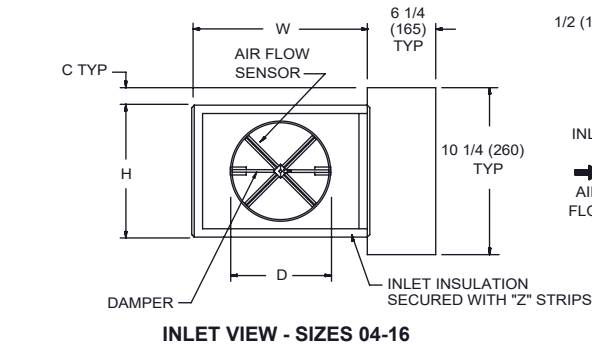

INLET VIEW - SIZES 04-16

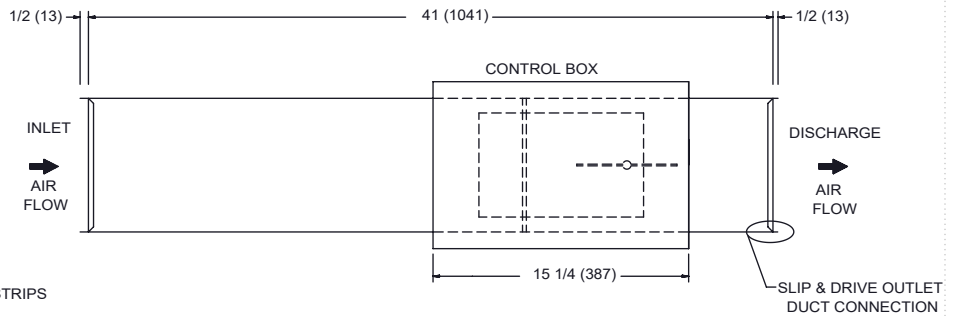

SIDE VIEW

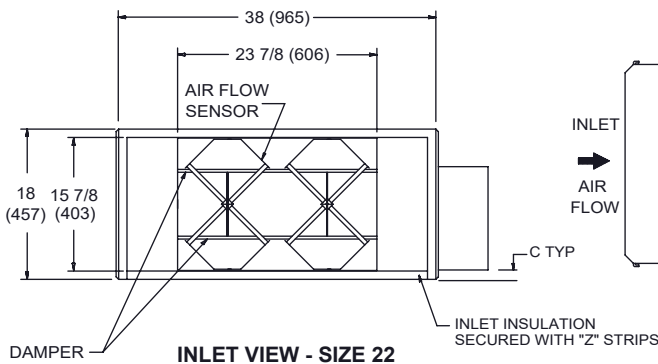

INLET VIEW - SIZE 22

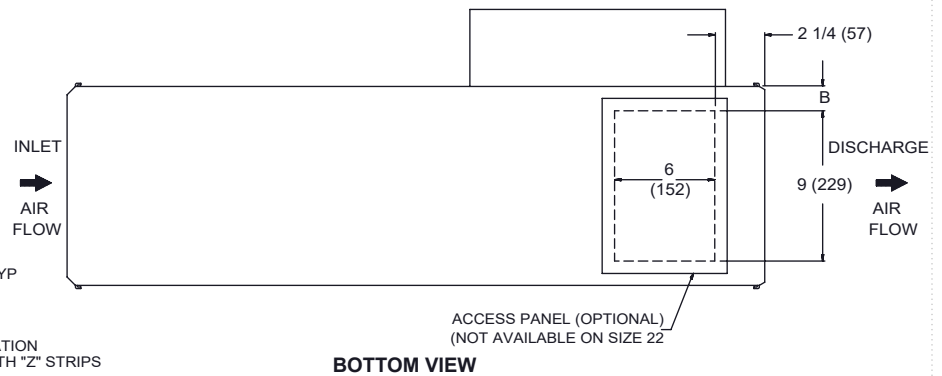

BOTTOM VIEW

### STANDARD FEATURES:

- 22 Ga. Zinc coated steel construction.
- Integrated inlet attenuator with slip and drive connections
- Metal Z strips along leading edge of insulation at inlet
- **NEMA 1** steel control enclosure for electric or electronic components
- 1/2" thick dual density fiberglass insulation meeting **NFPA 90A** and **UL 181** safety requirements.
- Four quadrant averaging cross flow sensor
- Variety of electric, analog, and digital control packages for pressure dependent and pressure independent systems.
- **ETL** listed - Adherence to **UL 429** for electrically operated valves.

**NOTE:** Right hand configuration shown, left hand available.

### DIMENSIONS ARE GIVEN AS INCHES (MM)

### OPTIONAL FEATURES:

- 20 Ga. Zinc coated steel construction
- Liners:  1/2" dual density fiberglass  None
- 1" dual density fiberglass  Steriliner
- Perforated double wall 1/2"  Sterilwall 1/2"
- Perforated double wall 1"  Sterilwall 1"
- 1/2" Cellular - fibre free  1" Cellular - fibre free
- Metal Z strips along edges of Steriliner insulation
- Linear averaging sensor.
- 24 Volt transformer
- Disconnect switch for electronic controls
- Dust tight control enclosure.
- Left hand control enclosure.
- Right hand control enclosure.
- Bottom access panel
- Cam lock bottom access panel
- Hanger Brackets

INLET SIZE	NOM MAX CFM(L/s)	W	H	B	C	D
4	230 (109)	12 (305)	8 (203)	1 1/2 (38)	2 1/8 (54)	3 7/8 (98)
5	360 (170)	12 (305)	8 (203)	1 1/2 (38)	2 1/8 (54)	4 7/8 (124)
6	520 (245)	12 (305)	8 (203)	1 1/2 (38)	2 1/8 (54)	5 7/8 (149)
7	710 (335)	12 (305)	10 (254)	1 1/2 (38)	1 1/8 (29)	6 7/8 (175)
8	925 (437)	12 (305)	10 (254)	1 1/2 (38)	1 1/8 (29)	7 7/8 (200)
9	1200 (566)	14 (356)	12 1/2 (318)	2 1/2 (64)	-	8 7/8 (225)
10	1450 (685)	14 (356)	12 1/2 (318)	2 1/2 (64)	-	9 7/8 (251)
12	2100 (991)	16 (406)	15 (381)	3 1/2 (89)	-	11 7/8 (302)
14	2900 (1369)	20 (508)	17 1/2 (445)	5 1/2 (140)	-	13 7/8 (352)
16	3700 (1746)	24 (610)	18 (457)	7 1/2 (191)	-	15 7/8 (403)
22	7100 (3351)	38 (965)	18 (457)	14 1/2 (368)	1 1/8 (29)	SEE ABOVE