

Introduction: KMS

The Krueger Measuring Station, model KMS, is designed to accurately measure airflow with a linear or four-quadrant multi-point differential pressure sensor. The KMS is designed to be installed in round duct work upstream of existing mechanical constant volume units, pressure dependent terminal units, or any other application requiring air flow measurement in round duct work.

MODEL

KMS - Krueger Measuring Station

FEATURES

- Round duct sizes 4" to 16" available.
- 22 Gage galvanized steel construction with optional 20 gage galvanized steel and stainless steel providing additional strength and durability.
- Airflow capacities from 40 to 3660 CFM Providing airflow measuring for most applications.
- LineaCross four-quadrant, multi-point center averaging sensor offers low resistance to airflow while providing an amplified velocity pressure signal. Optional linear, multi-point averaging velocity sensor.

* Value is based on a signal of 0.03" WG differential pressure of the inlet sensor. Minimum may be 0.

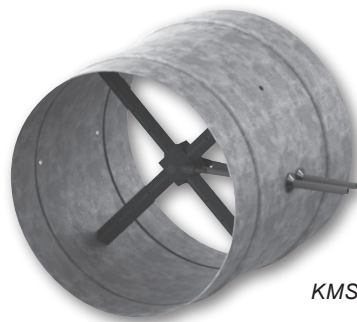

KMS

KMS Unit Capacities

KMS, UNIT CAPACITIES

Inlet Size	Airflow CFM [L/s]	
	Max.	Min.*
04	230 [109]	40 [19]
05	360 [170]	62 [29]
06	515 [243]	89 [42]
07	700 [330]	121 [57]
08	920 [434]	159 [75]
09	1160 [547]	201 [95]
10	1430 [675]	248 [117]
12	2060 [972]	357 [168]
14	2800 [1321]	486 [229]
16	3660 [1727]	634 [299]

KMS Dimensional Information

KMS, INLET VIEW WITH LINEAR PROBE SENSOR

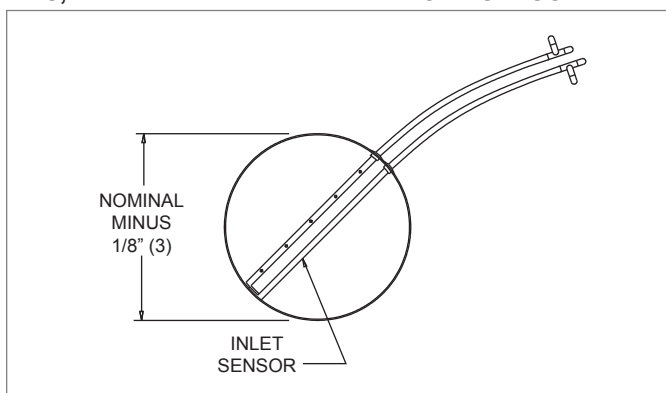

KMS, INLET VIEW WITH LINEACROSS SENSOR

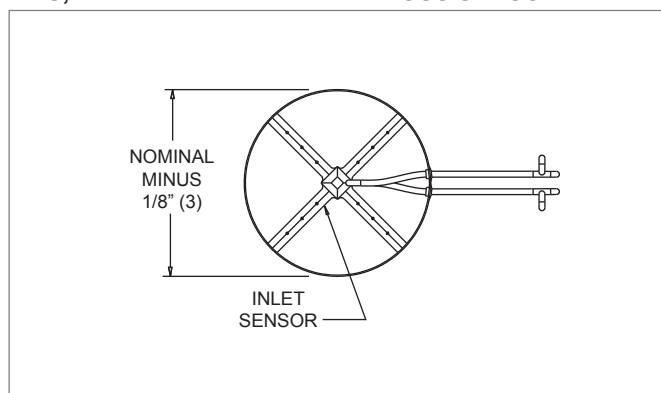

KMS, SIDE VIEW (SIZES 4 & 5)

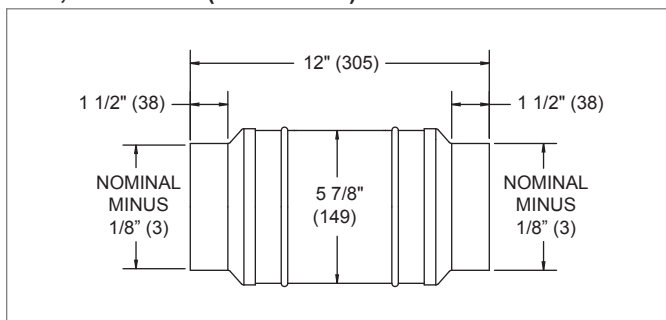

KMS, SIDE VIEW (SIZES 6 - 16)

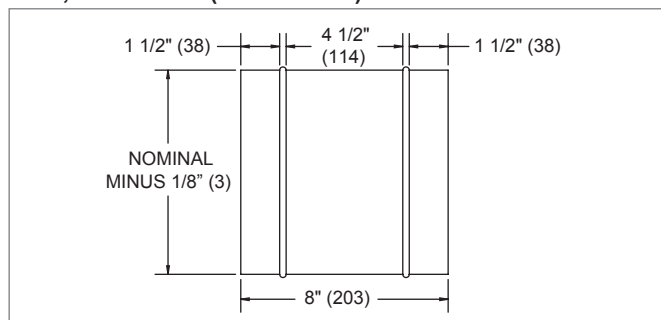

NOTE: Dimensions in parentheses are mm.

RETROFIT/BYPASS TERMINAL UNITS

KMS