

**RadiaFlo RF Series**  
*1-Way, 90°, Radial Air Diffusion*
**SUBMITTAL SHEET**

UNIT SIZE		NECK SIZE
48" X 24"	24" X 24"	
<input type="checkbox"/> 10"	<input type="checkbox"/> 08"	
<input type="checkbox"/> 12"	<input type="checkbox"/> 10"	

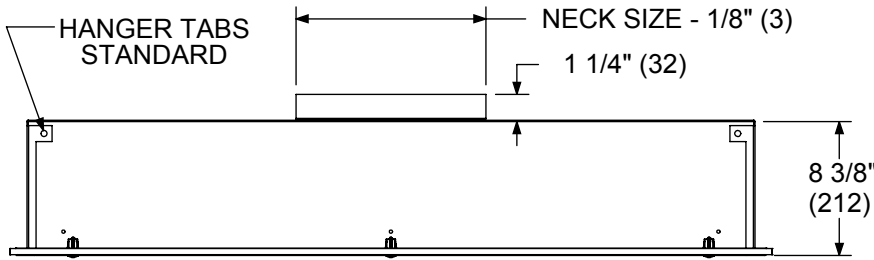
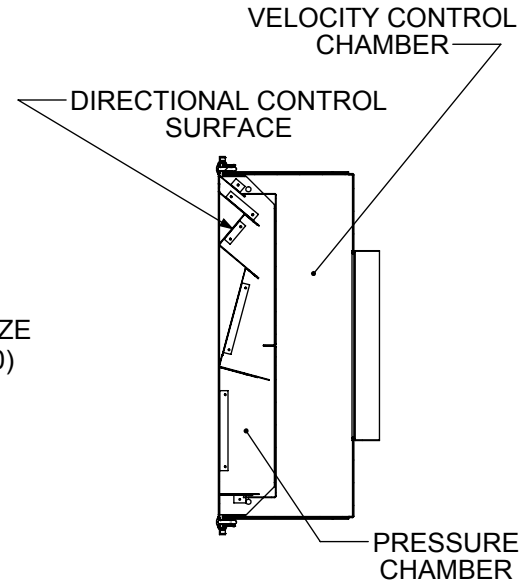
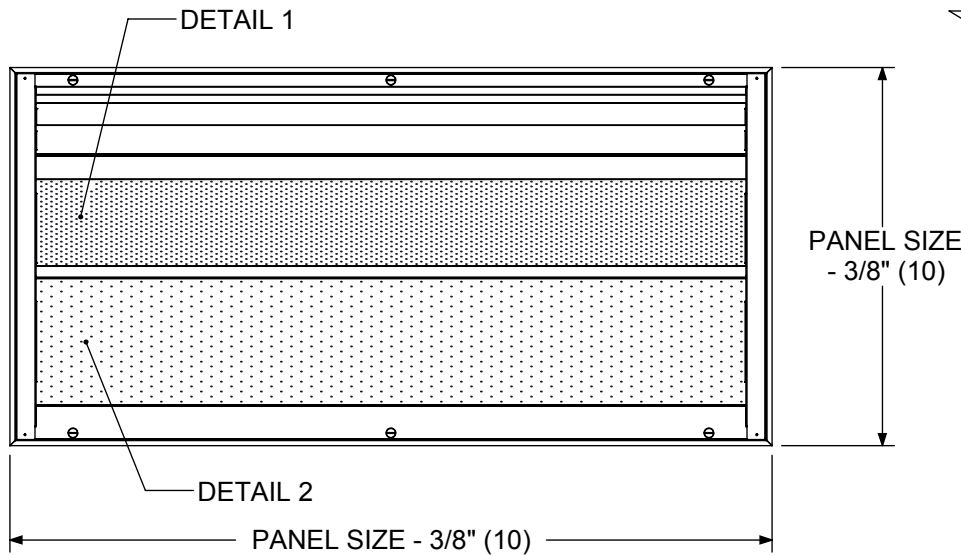
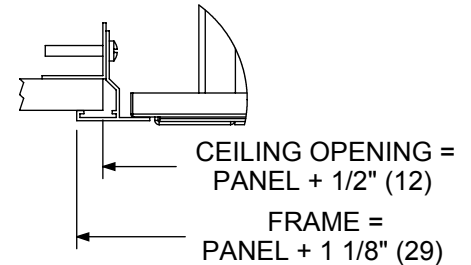
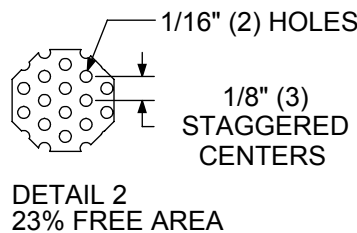
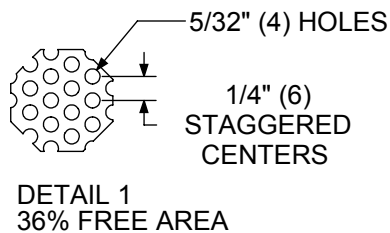

FACE:  ALUMINUM (5RF)  STAINLESS (9RF)  STEEL  
 BACKPAN:  ALUMINUM  STAINLESS  STEEL

**NOTES:**

- NON-INTRUSIVE FACE DESIGN
- FACE AND BACKPAN ARE COMPLETE ASSEMBLY
- MULTIPLE PANEL PERFORATED FACE FOR SUPERIOR PERFORMANCE
- FACE IS EASILY REMOVABLE FOR CLEANING UTILIZING 1/4 TURN FASTENERS
- FACE AVAILABLE IN ALUMINUM (5RF) OR STAINLESS (9RF)
- BACKPAN AVAILABLE IN ALUMINUM, STAINLESS, OR STEEL
- STANDARD FINISH IS #44 WHITE. OTHER FINISHES AVAILABLE
- AVAILABLE IN 48"X24" OR 24"X24" PANEL--SEE CHART FOR NECK SIZES
- T-BAR MOUNT (F23) STANDARD. OPTIONAL HARD CEILING MOUNT (F22) WITH SUPPLIED 5HCF23 FRAME

FRAME 22 – SURFACE MOUNT  
 (SHOWN WITH SUPPLIED  
 5HCF23 FRAME)

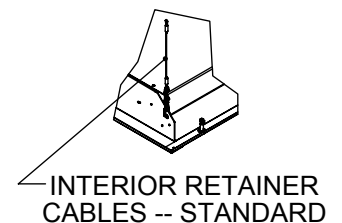

DIMENSIONS GIVEN AS  
 INCHES (MM)