

SUBMITTAL SHEET

Form Number DS0825

Effective Date 7/07

Replaces NEW

JOB NAME _____
ARCHITECT _____
ENGINEER _____
CONTRACTOR _____
LOCATION _____

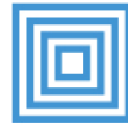

KRUEGER

Excellence in Air Distribution

Powered by:  RICKARD

VPQ-1, VPQ-4 RELIEF RING ASSEMBLY

PART NUMBER	D	D + 2"
31636601	3 7/8"	6"
31636602	5 7/8"	8"
31636603	7 7/8"	10"
31636604	9 7/8"	12"

D = DUCT CONNECTION
D+2" = NECK SIZE

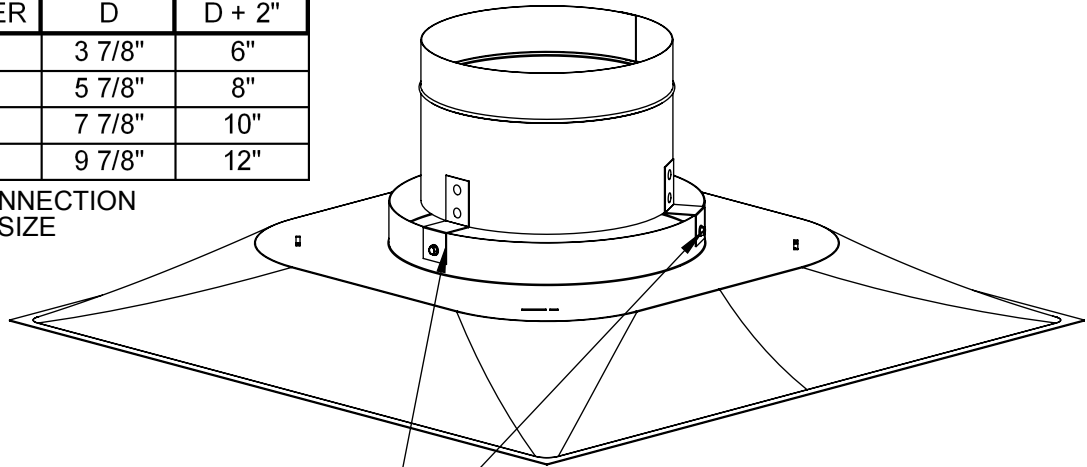

**QTY 3, #8 X 1/2" SCREWS
(FIELD SUPPLIED)**

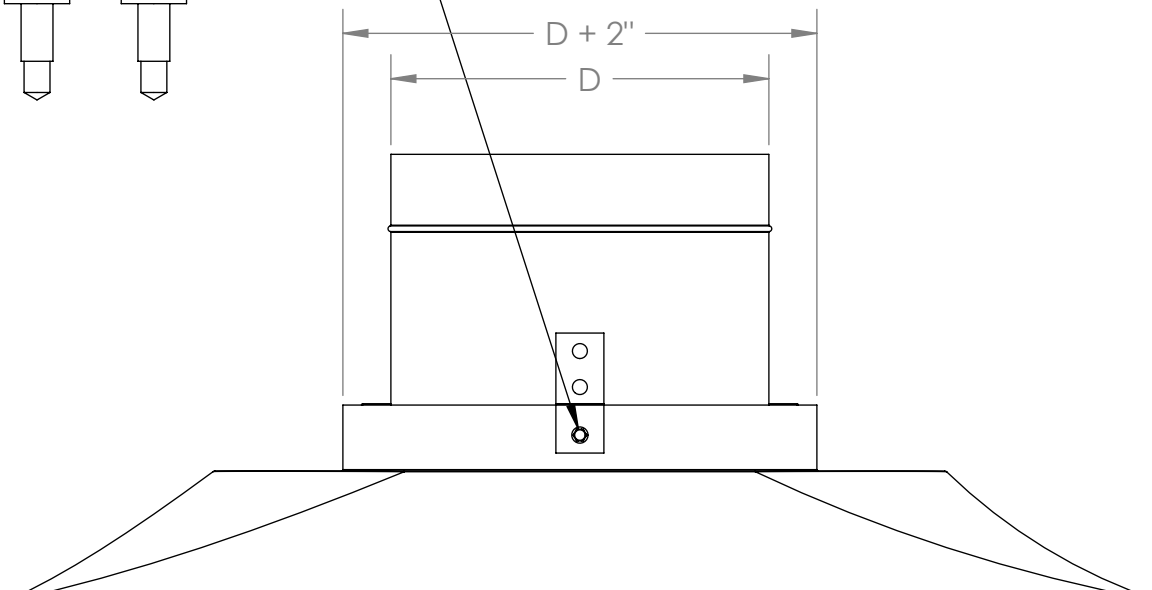
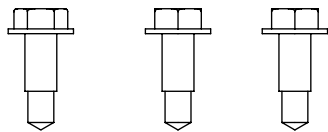

**NOTE:
RELIEF RING MILL FINISH
SHIPPED SEPARATE, FIELD INSTALLED
DIFFUSER NECK MUST BE UPSIZED
2" OVER RING SIZE**