

# SUBMITTAL SHEET

PANEL SIZE	A	B	C	WEIGHT LB (kg)
24 X 24	23.63 (600)	23.85 (606)	21.37 (543)	41 (19)
24 X 48	47.63 (1210)	47.85 (1215)	45.37 (1152)	66 (30)

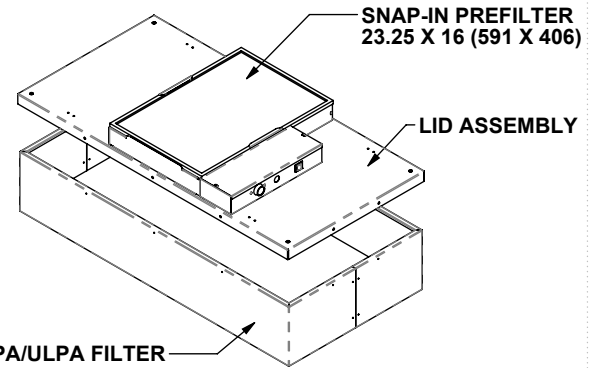
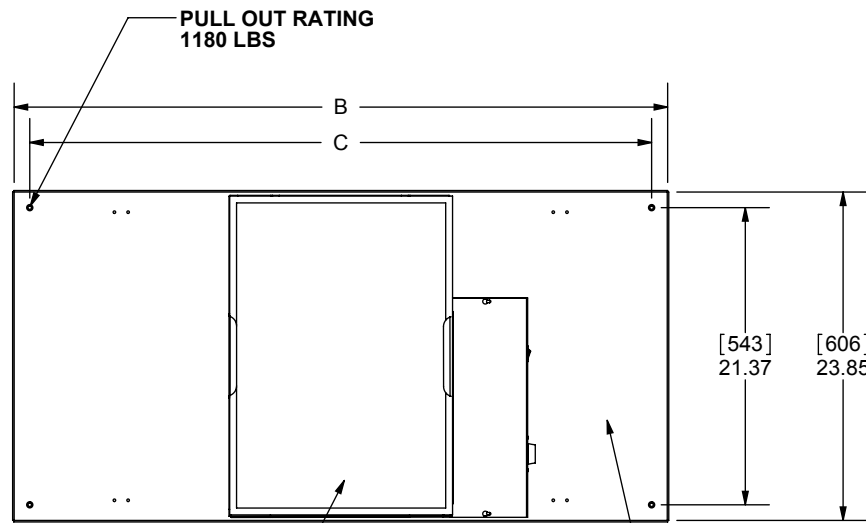

SNAP-IN PREFILTER  
23.25 X 16 (591 X 406)

WALKABLE PLENUM  
250 LBS MAX

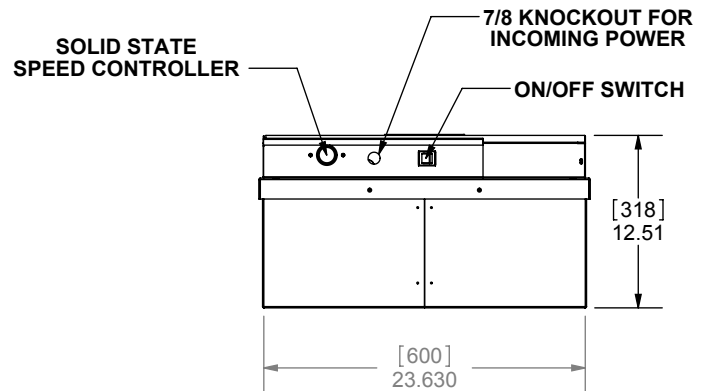
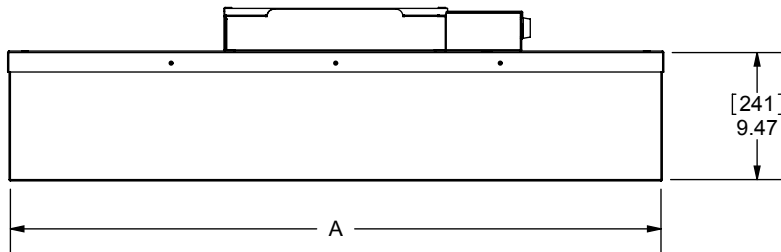
**Features:**

- Snap-In Prefilter
- Forward Inclined Centrifugal Fan
- Lay-in Frame (Surface mount requires Accessory 4 option selected)
- Meets UL507, UL900, IEST Recommended Practices

**Available Parts (Ordered Separately):**

- Round Duct Collar 10" (p/n:10691) or 12" (p/n:10789)
- 115V Power Cord (p/n:S24344-001) (non-UL)
- Replacement Prefilter (p/n:62981)

**Options:**
**PSC Motor w/ SSSC**

- 115V (3.0 FLA)
- 208-240V (1.5 FLA)
- 277V (1.2 FLA)

**Filter**

- HEPA 99.99% @ 0.3 Micron UL900
- ULPA 99.9995% @ 0.12 Micron UL900
- Unit must be removed from ceiling to replace filter

**Accessories**

- Filter Indicator Light (red)
- Run Indicator Light (green)
- Continuous Filter Monitor
- Challenge/Pressure Ports
- Insulation
- Surface Mount Frame

**Finish**

- 01 Mill Aluminum Casing with White Diffuser Screen
- 44 White Aluminum Casing with White Diffuser Screen
- 90 304 SS Casing with 304 SS Diffuser Screen
- 91 Mill Aluminum Casing with 304 SS Diffuser Screen