

NOA
NECK OFFSET ADAPTER

SUBMITTAL SHEET

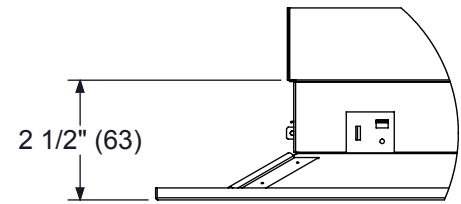

**FACE TO NECK DIMENSION
 (SCREWS NOT SHOWN)**

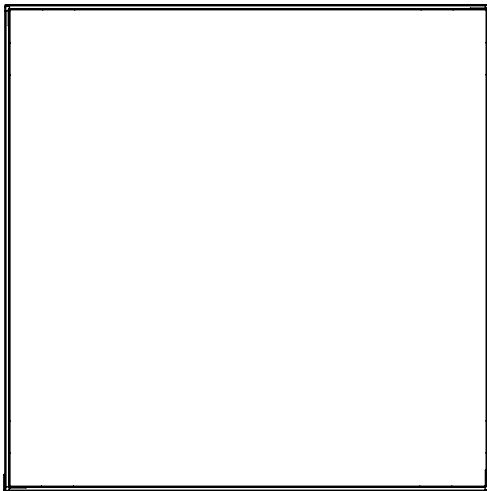
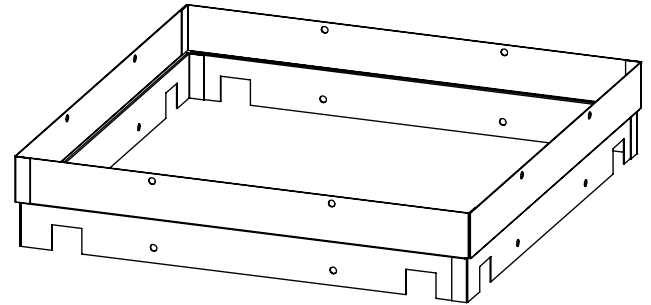
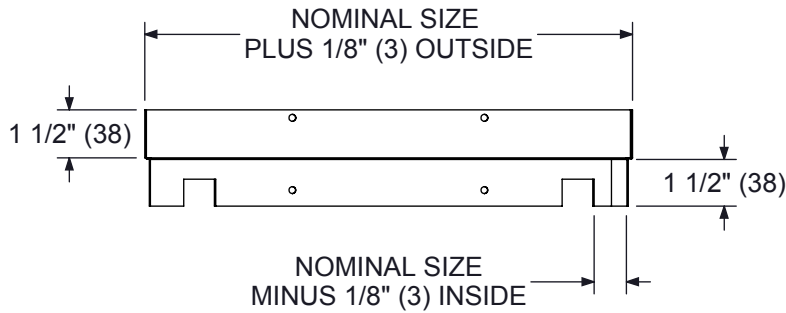
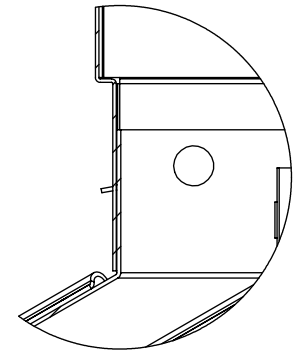

**OFFSET NECK ADAPTER
 SHOWN WITH DIFFUSER
 (SCREWS NOT SHOWN)**

NOTES:

1. AVAILABLE IN NOMINAL NECK WIDTHS & HEIGHTS OF 6" THRU 21"
2. STANDARD CONSTRUCTION IS 22 GA. GALVANIZED STEEL
3. STANDARD FINISH IS MILL
4. UNITS FROM 6"-9" WILL HAVE TWO SCREW PER SIDE, UNITS FROM 12"-21" WILL HAVE FOUR SCREWS PER SIDE
5. NOT AVAILABLE WITH LINEAR STRAIGHTENING GRID
6. COMPATIBLE WITH OBDDM, ORDERED SEPARATELY.