

Model | KBH & KBV

KBH

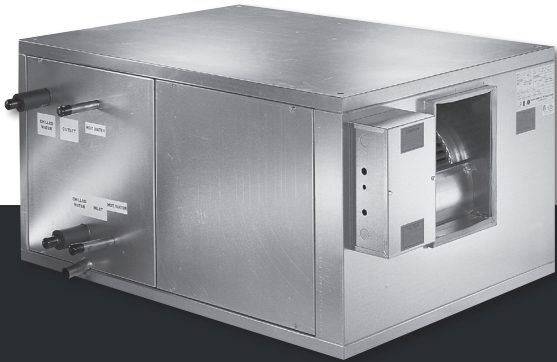

KBV



INSTALLATION, OPERATION & MAINTENANCE MANUAL

For Horizontal & Vertical Belt Drive Blower Coil Units

TABLE OF CONTENTS

General Safety Guidelines & Safety Symbols	3
Safety Considerations	4
Pre Start-Up	5
Field Wiring	5
Belts, Drives, & Bearings	7
Determining Deflection Force	7
Replacement Parts	8
Piping	8
Condensate Drain & Traps	9
General Belt and Bearing Maintenance	10
Motor & Weight Data (Motor Electrical Data, Unit Weight Data, Motor/Drive Weight Data)	11
Inspection & Start-Up Checklist	12

IMPORTANT!
READ BEFORE PROCEEDING!

GENERAL SAFETY GUIDELINES

The equipment covered by this manual is designed for safe and reliable operation when installed and operated within its design specification limits. To avoid personal injury or damage to equipment or property while installing or operating this equipment, it is essential that qualified, experienced personnel perform these functions using good judgment and safe practices. *See the following cautionary statements.*

SAFETY SYMBOLS

The following symbols are used in this document to alert the reader to areas of potential hazard:



DANGER - Indicates an imminently hazardous situation, which, if not avoided, will result in death or serious injury.



WARNING - Indicates a potentially hazardous situation, which, if not avoided, could result in death or serious injury.



CAUTION - Identifies a hazard which could lead to damage to the machine, damage to other equipment and/or environmental pollution. Usually an instruction will be given, together with a brief explanation.



NOTE - Used to highlight additional information, which may be helpful to you.

SAFETY CONSIDERATIONS



DANGER - ELECTRICAL SHOCK HAZARDS. All power must be disconnected prior to installation and servicing this equipment. More than one source of power may be present. Disconnect all power sources to avoid electrocution or shock injuries.



DANGER - MOVING PARTS HAZARDS. Motor and Blower must be disconnected prior to opening access panels. Motors can start automatically, disconnect all power and control circuits prior to servicing to avoid serious crushing or dismemberment injuries.



DANGER - HOT PARTS HAZARDS. Electric Resistance heating elements must be disconnected prior to servicing. Electric Heaters may start automatically, disconnect all power and control circuits prior to servicing to avoid burns.



WARNING - Check that the unit assembly and component weights can be safely supported by rigging and lifting equipment.



WARNING - All assemblies must be adequately secured during lifting and rigging by temporary supports and restraints until equipment is permanently fastened and set in its final location.



WARNING - All unit temporary and permanent supports must be capable of safely supporting the equipment's weight and any additional live or dead loads that may be encountered. All supports must be designed to meet applicable local codes and ordinances.



WARNING - All fastening devices must be designed to mechanically lock the assembly in place without the capability of loosening or breaking away due to system operation, vibration, impact or seismic event.



CAUTION - Secure all dampers when servicing damper, actuator or linkages. Dampers may activate automatically, disconnect control circuits or pneumatic control systems to avoid injury.



CAUTION - Protect adjacent flammable materials when brazing. Use flame and heat protection barriers where needed. Have fire extinguisher available and ready for immediate use.

PRE START-UP & FIELD WIRING



WARNING - Improper installation, adjustment, alterations, service or maintenance can cause injury and property damage, as well as possible voiding of factory warranty. For assistance or additional information, consult a qualified contractor.

RECEIVING AND INSPECTING

Thoroughly examine the exterior and interior of all units for transportation damage to the cabinet, piping, blower(s), motor(s), coil(s), electric heat and electrical components. Interior damage may occur, even with no visible exterior damage. If damage is found, immediately file a claim with the carrier. Note the damage on the bill of lading before signing for the shipment.

Check the bill of lading for verification that all items shown (including loose items) have been received. Notify the manufacturer's representative of any shortages or items shipped in error.

UNIT RIGGING AND PLACEMENT:

Install ductwork to comply with ASHRAE Fundamentals Handbook, SMACNA, NFPA 90A and local code.

The installation must conform with local building codes and the National Electric Code.

Locate unit support in accordance with the mechanical and structural plans. If so equipped, locate the isolator placement and correct size as shown on the submittal drawing.

Ceiling suspension of horizontal units have factory provisions for thru bolt hanger rods, except double wall units (which require external rigging). If floor mount isolators are required for either horizontal or vertical units, then factory or field provisions must be made for isolator attachment. Vertical units can be mounted directly to the floor or on a base rail. For units with isolators but no base rail, 6" legs are required and will need to be mounted to the base of the unit. If a base rail is provided, isolators can be installed in mounting holes provided on this base rail.

Do not handle the unit using coil stubout connectors, as damage may occur at brazed joint(s).

CLEARANCE

All units, including those with electric heat, are listed for zero clearance to combustibles.

Sufficient clearance for normal servicing of this equipment is recommended.

All electrical panels must have 36" working space in front of panel to meet National Electric Code; however, local inspectors may waive this requirement if the hinged cover has a 90° free swing.

FIELD WIRING



NOTE - Prior to installing any wiring, check the unit name plate for main power voltage, control voltage, transformer sizing and any fuse sizing. All field wiring must comply with National Electric Code and local code requirements.

Tighten all wiring lugs and terminals prior to connecting power to the unit, as they may loosen during transportation.

Route the power lines to the power distribution terminals inside the control enclosure. If a factory wired disconnect switch is installed, then connect the power lines to the line side of the switch.

Mount and wire any field installed items as indicated on the factory supplied wiring diagram. When mounting field installed components, do not jumper out or rewire any factory wiring without written approval from Krueger. Violation will void warranty.

PRE START-UP & FIELD WIRING



CAUTION - * It is critical to the installation of the AHU unit that the mechanical fastener used form a “mechanical lock” so that it is incapable of backing off due to vibration. Serious injury and/or property damage may occur if not properly addressed.

FIGURE 1 - HORIZONTAL UNIT (ALL SIZES) WITHOUT OPTIONAL BASE RAIL

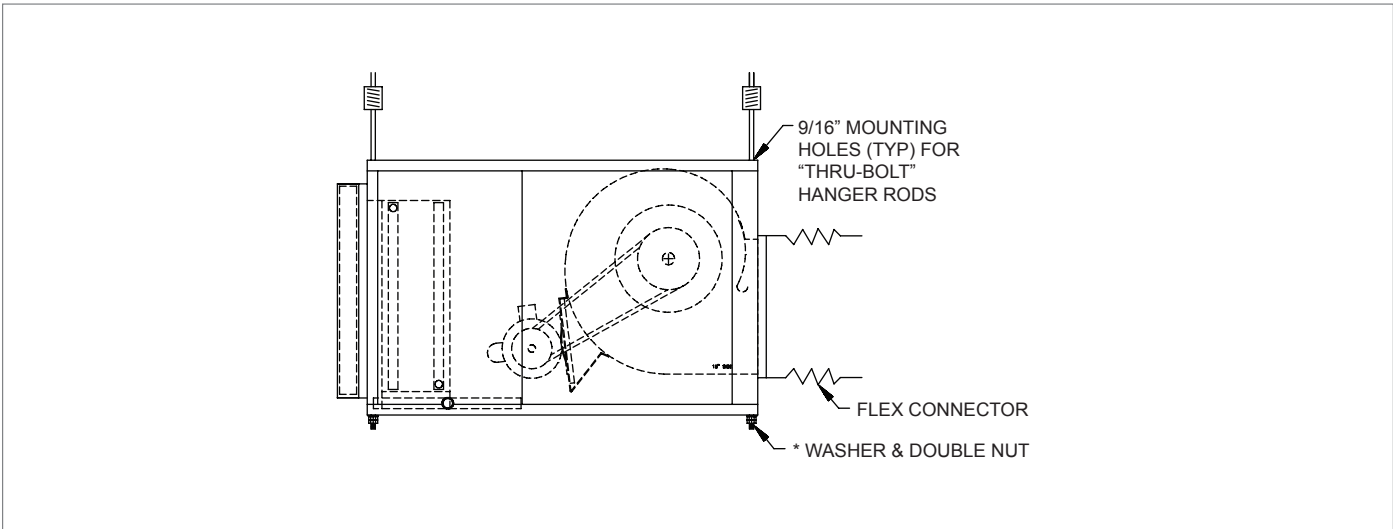
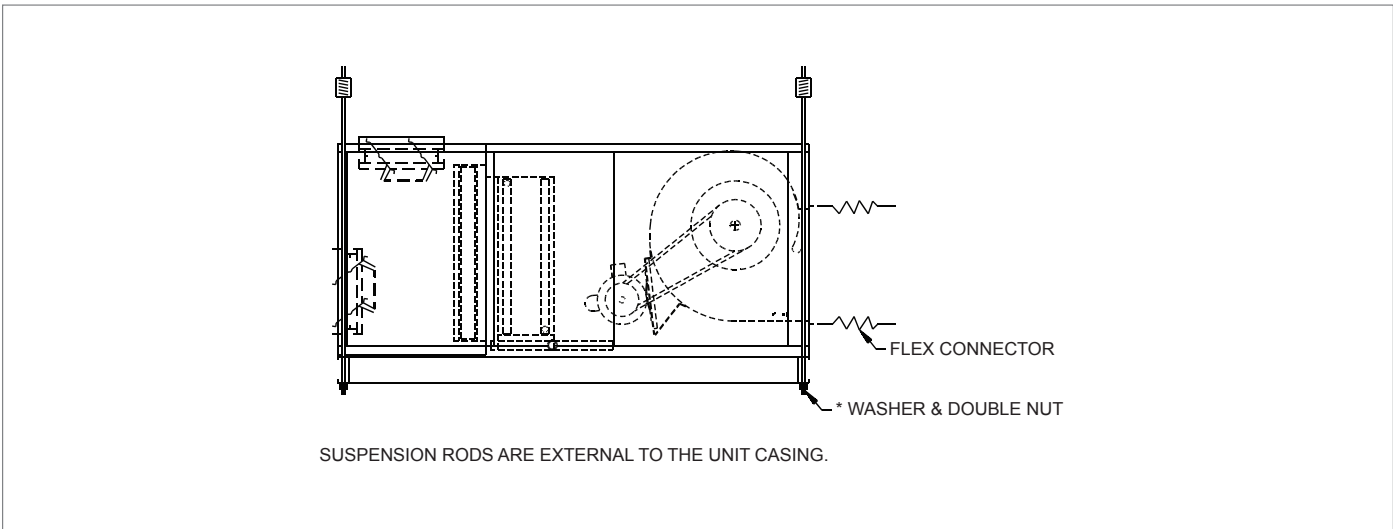

FIGURE 2 - HORIZONTAL UNIT (ALL SIZES) WITH BASE RAIL



BELTS, DRIVES & BEARINGS



NOTE - For safety, please turn off all power before checking belt tension.

Prior to starting the unit, tighten all set screws on the fan(s), sheaves and bearings where applicable. Set screws may loosen during transportation.

Sheaves must be in line. Use a straight edge to verify.

General Belt Tension Rules for V-Belt Drives:

- Ideal tension is the lowest tension at which the belt will not slip under peak load conditions.
- Check tension frequently during the first 24-48 hours of operation.
- Over tensioning shortens belt and bearing life.
- Keep belts free from foreign material which may cause slip.
- Make V-Belt inspection on a periodic basis. Tension when slipping. Never apply belt dressing, as this will damage the belt and cause early failure.
- The resilient blower bearing must not deflect laterally once belt is tightened.

DETERMINING DEFLECTION FORCE

BELT TYPE	SMALLEST SHEAVE DIAMETER RANGE	RPM RANGE	DEFLECTION FORCE (LBS.)			
			SUPER GRIPBELTS & UNNOTCHED GRIPBANDS		GRIPNOTCH BELTS & NOTCHED BANDS	
			USED BELT	NEW BELT	USED BELT	NEW BELT
A, AX	3.0 - 3.6"	1000 - 2500	3.7	5.5	4.1	6.1
	3.8 - 4.8"	1000 - 2500	4.5	6.8	5.0	7.4
	5.0 - 7.0"	1000 - 2500	5.4	8.0	5.7	9.4
B, BX	3.4 - 4.2"	860 - 2500	NOT Recommended		4.9	7.2
	4.4 - 5.6"	860 - 2500	5.3	7.9	7.1	10.5
	5.8 - 8.6"	860 - 2500	6.3	9.4	8.5	12.6

FIGURE 3 - COMPUTING DEFLECTION FORCE

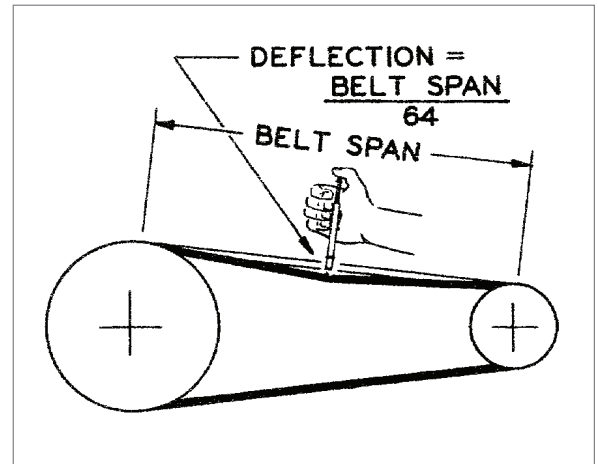

See table left for deflection force in pounds.

EXAMPLE	SOLUTION
Belt Span = 20" Belt Type – A, new, unnotched RPM = 1000 Small Sheave Diameter = 4.0"	$\text{Deflection} = 20 \div 64 = .313"$ (round to 5/16"). Referring to table below, deflection force at calculated deflection is 6.8lbs

See FIG 3 (right).

REPLACEMENT PARTS

Replacement parts may be ordered from the local Krueger representative. Factory replacement parts should be used wherever possible to maintain agency listings. Should replacement parts not be purchased from the factory, use only parts duplicating the exact type, size, voltage and other operating characteristics of the original part. Contact the local representative before using any substitute part or making unit modifications. Any substitutions and/or modifications not authorized by the factory will void the unit warranty and could result in personal injury and/or property damage.

When ordering parts, the following information must be supplied to ensure proper part identification:

1. Complete unit model number.
2. CO number from the unit nameplate.
3. Complete parts description, including any identification numbers.

PIPING

- All piping must comply with applicable state and local codes.
- On water coils, the piping must be in a counterflow configuration; water inlet on the leaving air side of the coil and at the bottom of the coil to provide the necessary purging of air.
- All water piping should be designed and installed to meet the job requirements.
- Where applicable, freeze protection should be used.
- Supply and return water piping should be supported. Do not suspend piping, controls, and/or shutoff valves from coil headers.
- All refrigerant piping (split systems) should be designed and installed in accordance with ARI and ASHRAE. Leak testing should be performed before any startup procedures are initiated. On refrigeration systems, follow recommended system evacuation from the condenser unit manufacturer.

CONDENSATE DRAIN & TRAPS

Drain lines should be at least the same size as the drain pan connection. Properly sized traps should be used to allow the condensate from the coils to drain from the drain pan. See FIG. 4 (below).

FIGURE 4 - CONDENSATE DRAIN & TRAPS

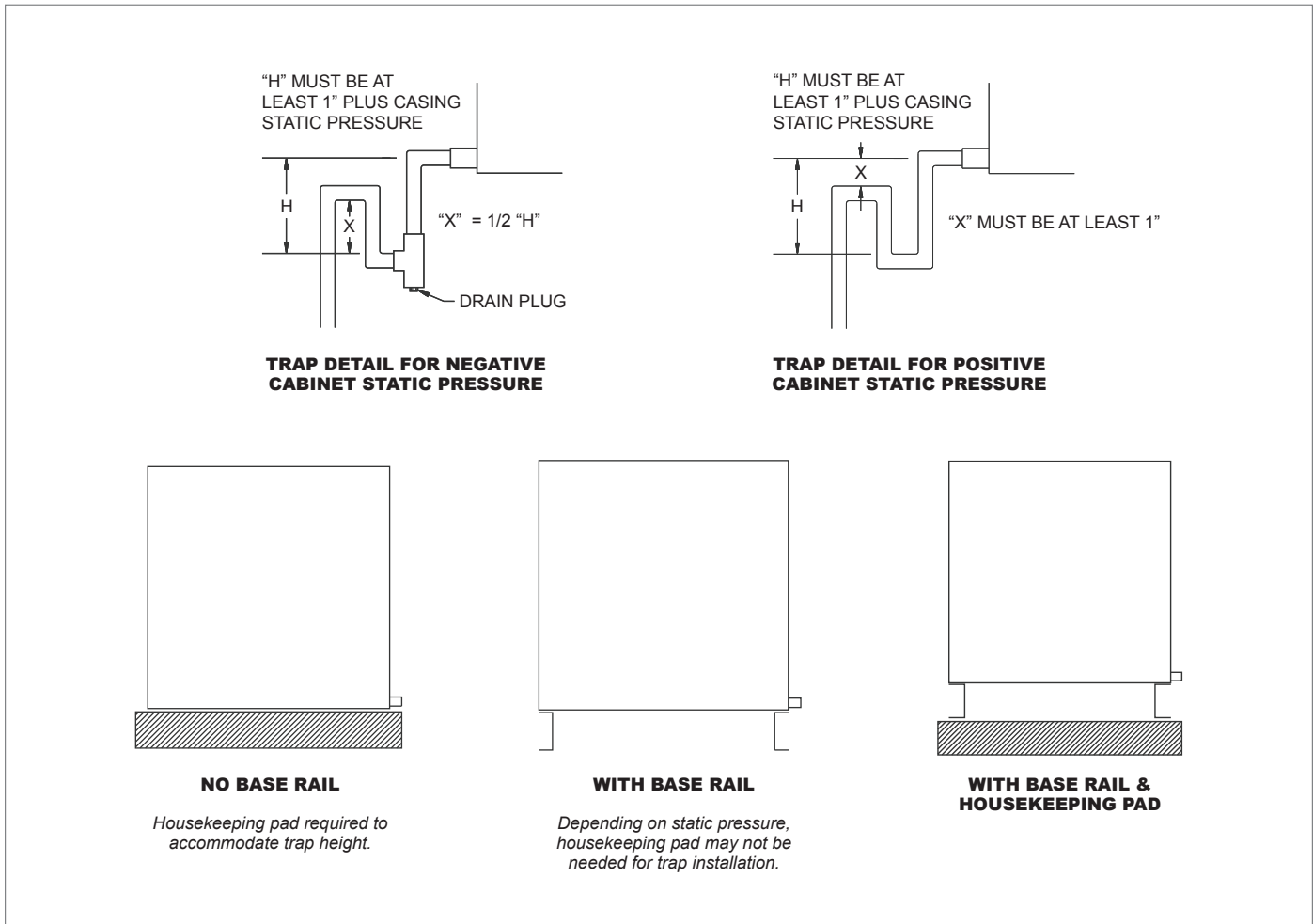

GENERAL BELT & BEARING MAINTENANCE



NOTE - This manual is not intended to supplant regulations or local codes having jurisdiction. It is recommended that these items be reviewed and completed prior to initiating equipment start-up.

Frequency of bearing re-lubrication depends upon the operating conditions. The proper amount of lubricant in the bearings is very important. Both excessive and inadequate lubrication may cause failure. The bearings should be re-lubricated while they are rotating (if it is safe to do so); the grease should be pumped in slowly until a slight bead forms around the seals. It is solely the owner's responsibility for maintaining a proper lubrication schedule. Failure to do so may cause substantial unit damage and voiding of the factory warranty. Note that only those bearings equipped with a grease fitting can be re-lubricated.

The following is a generic guide intended for standard equipment used in common situations.

MAINTENANCE TO BE PERFORMED	EVERY 3 MONTHS OF OPERATION (MINIMUM)	EVERY FALL
Filters (As Required)	X	
Grease Bearings	X	
Inspect & Clean Blower Wheel		X
Lubricate Fan Motor (If Applicable)		X
Check Belt Tension	X	
Check Electrical Connections		X
Check Bearings, Drives & Blower Wheel For Tightness		X

Normal operation is based on 8 hours a day. If unit runs more than this, adjust accordingly.

RECOMMENDED TORQUE FOR TIGHTENING SET SCREWS		
SET SCREW DIAMETER	MINIMUM RECOMMENDED TORQUE	
	INCH LBS.	FOOT LBS.
#10	28	2.3
1/4	66	5.5
5/16	126	10.5
3/8	228	19.0
7/16	348	29.0
1/2	504	42.0
5/8	1104	92.0

MOTOR & WEIGHT DATA

MOTOR ELECTRICAL DATA

HORSEPOWER	MAXIMUM MOTOR AMPERAGE							
	VOLTAGE							
	115/1	208/1	230/1	277/1	208/3	230/3	460/3	575/3
1/3	6.3	3.5	3.2	2.6	1.7	1.5	0.8	-
1/2	7.8	4.3	3.9	3.6	2.2	2.1	1.1	0.9
3/4	10.6	5.4	5.3	5.0	3.2	3.0	1.5	1.2
1	15.0	8.3	7.5	5.5	4.0	3.6	1.8	1.4
1-1/2	-	-	-	-	5.3	5.0	2.5	1.9
2	-	-	-	-	7.0	6.4	3.2	2.5
3	-	-	-	-	9.1	9.0	4.5	3.2
5	-	-	-	-	14.2	12.8	6.4	5.2

Actual motor nameplate AMPs may vary, but will not exceed values shown. Consult factory for applications requiring special motors.

UNIT WEIGHT DATA

COMPONENT	UNIT SIZE						
	08	12	16	20	30	40	
Base Unit	135 [61]	157 [71]	177 [80]	200 [90]	290 [131]	360 [163]	
Damper Section	46 [21]	54 [24]	65 [29]	90 [41]	105 [46]	162 [73]	
Blow Thru Electric Heater	42 [19]	42 [19]	42 [19]	50 [23]	55 [25]	55 [25]	
Coil Rows	1 Row - Dry	12 [5]	14 [6]	17 [8]	21 [10]	26 [12]	32 [15]
	1 Row - Wet	14 [6]	16 [7]	20 [9]	25 [11]	32 [15]	41 [19]
	2 Row - Dry	17 [8]	21 [10]	26 [12]	33 [15]	42 [19]	52 [24]
	2 Row - Wet	21 [10]	26 [12]	32 [15]	42 [19]	54 [25]	69 [31]
	3 Row - Dry	23 [10]	28 [13]	35 [16]	45 [20]	57 [26]	72 [33]
	3 Row - Wet	29 [13]	36 [16]	44 [20]	59 [27]	75 [34]	95 [43]
	4 Row - Dry	29 [13]	35 [16]	44 [20]	57 [26]	73 [33]	91 [41]
	4 Row - Wet	37 [17]	45 [20]	56 [25]	74 [34]	96 [44]	121 [55]
6 Row - Dry	40 [18]	49 [22]	62 [28]	81 [37]	104 [47]	132 [60]	
6 Row - Wet	52 [24]	64 [29]	81 [37]	106 [48]	138 [63]	178 [81]	

Unit weight data is shipping weight in pounds [kilograms].

MOTOR/DRIVE WEIGHT DATA

TYPE	MOTOR HP							
	1/3	1/2	3/4	1	1 1/2	2	3	5
Single Phase	37 [17]	37 [17]	45 [20]	47 [21]	-	-	-	-
Three Phase	34 [15]	34 [15]	40 [18]	43 [20]	46 [21]	53 [24]	81 [37]	94 [43]

Includes motor, pulleys, belts, and motor base. Motor/drive weight data is shipping weight in pounds [kilograms].

INSPECTION & START-UP CHECKLIST

<p>Receiving and Inspection</p> <p><input type="checkbox"/> Unit Received Undamaged</p> <p><input type="checkbox"/> Unit Arrangement/Hand Correct</p> <p><input type="checkbox"/> Unit Received Complete as Ordered</p> <p><input type="checkbox"/> Unit Structural Support Complete and Correct</p>	<p>Electrical Connections</p> <p><input type="checkbox"/> Refer to Unit Wiring Diagram</p> <p><input type="checkbox"/> All Field Wiring in Code Compliance</p> <p><input type="checkbox"/> Connect Incoming Power Service or Services</p>
<p>Handling and Installation</p> <p><input type="checkbox"/> Unit Mounted Level and Square</p> <p><input type="checkbox"/> Proper Electrical Service Provided</p> <p><input type="checkbox"/> Proper Service Switch/Disconnect Provided</p> <p><input type="checkbox"/> Proper Chilled Water Line Size to Unit</p> <p><input type="checkbox"/> Proper Refrigerant Line Sizes to Unit</p> <p><input type="checkbox"/> Proper Steam Condensate Trap on Return Line</p> <p><input type="checkbox"/> All Services to Unit in Code Compliance</p> <p><input type="checkbox"/> Proper Access Provided for Unit and Accessories</p> <p><input type="checkbox"/> Proper Overcurrent Protection Provided</p> <p><input type="checkbox"/> Proper Hot Water Line to Unit</p> <p><input type="checkbox"/> Proper Steam Line Sizes to Unit</p> <p><input type="checkbox"/> Proper Steam Supply Pressure to Unit (15psi Max)</p> <p><input type="checkbox"/> All Shipping Screws and Braces Removed</p> <p><input type="checkbox"/> Proper Mechanical Fasteners Used for All Horizontal Ceiling Hung Units</p>	<p>Unit Startup</p> <p><input type="checkbox"/> General Visual Unit and System inspection</p> <p><input type="checkbox"/> Record Ambient Temperature</p> <p><input type="checkbox"/> Close All Unit Isolation Valves</p> <p><input type="checkbox"/> Fill Systems with Water/Refrigerant</p> <p><input type="checkbox"/> All Ductwork and Grilles in Place</p> <p><input type="checkbox"/> Start Fans, etc.</p> <p><input type="checkbox"/> Check All Ductwork and Units for Air Leaks</p> <p><input type="checkbox"/> Record All Final Settings for Future Use</p> <p><input type="checkbox"/> Check All Dampers for Proper Operation</p> <p><input type="checkbox"/> Verify Proper Heating Operation</p> <p><input type="checkbox"/> Record Electrical Supply Voltage</p> <p><input type="checkbox"/> Check All Wiring for Secure Connections</p> <p><input type="checkbox"/> Flush Water Systems</p> <p><input type="checkbox"/> Vent Water Systems as Required</p> <p><input type="checkbox"/> All Unit Panels and Filters in Place</p> <p><input type="checkbox"/> Check for Overload Condition of All Units</p> <p><input type="checkbox"/> Balance Air Systems as Required</p> <p><input type="checkbox"/> Check Piping and Ductwork for Vibration</p> <p><input type="checkbox"/> Verify Proper Cooling Operation</p> <p><input type="checkbox"/> Reinstall All Covers and Access Panels</p>
<p>Cooling/Heating Connections</p> <p><input type="checkbox"/> Protect Valve Package Components From Heat</p> <p><input type="checkbox"/> Connect Field Piping to Unit</p> <p><input type="checkbox"/> Install Drain Line and Traps as Required</p> <p><input type="checkbox"/> Install Condensate Pan Under Piping as Required</p> <p><input type="checkbox"/> Mount Valve Packages</p> <p><input type="checkbox"/> Pressure Test All Piping for Leaks</p> <p><input type="checkbox"/> Insulate All Piping as Required</p>	<p>Blower/Motor</p> <p><input type="checkbox"/> Check Sheave Set Screw Tightness</p> <p><input type="checkbox"/> Check Blower Wheel Set Screw Tightness</p> <p><input type="checkbox"/> Adjust Blower Speed as Necessary for Balancing Airflow</p> <p><input type="checkbox"/> Check/Adjust Sheave Alignment</p> <p><input type="checkbox"/> Check/Adjust Belt Tension</p>
<p>Ductwork Connections</p> <p><input type="checkbox"/> Install Ductwork, Fittings, and Grilles as Required</p> <p><input type="checkbox"/> Control Outside Air for Freeze Protection</p> <p><input type="checkbox"/> Proper Supply and Return Grille Type and Size Used</p> <p><input type="checkbox"/> Insulate All Ductwork as Required</p>	



1401 N. Plano Rd. | Richardson, TX 75081 | Tel: 972.680.9136 | Fax: 972.497.0450
www.krueger-hvac.com | kruegerinfo@krueger-hvac.com