

ATTENUATOR | DIMENSIONAL DATA

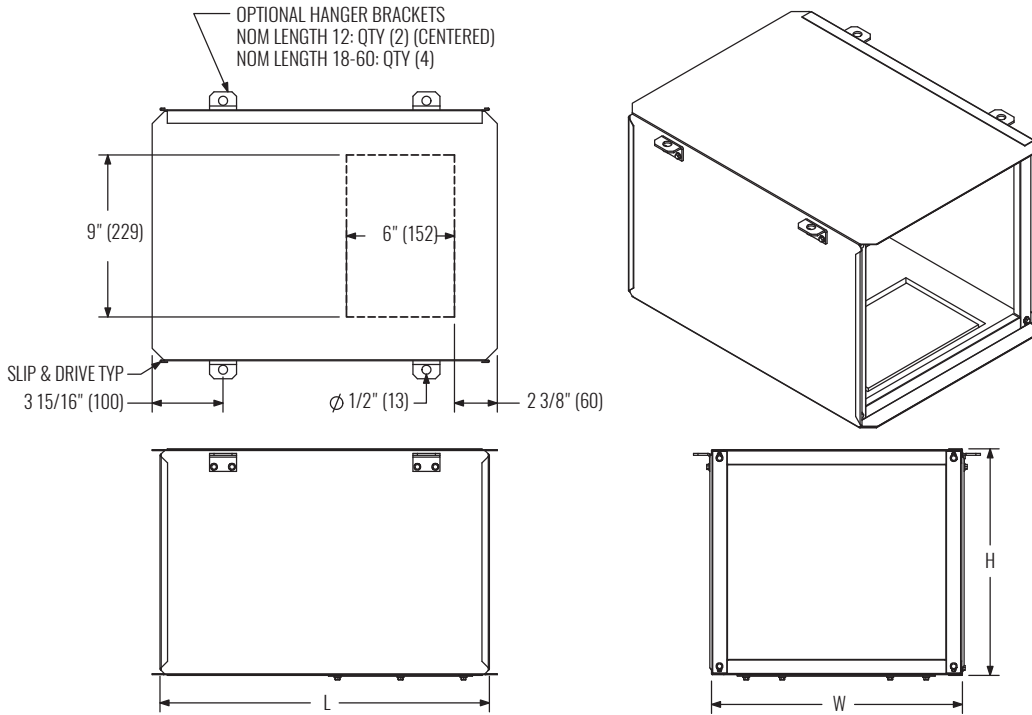

Dimensions in parentheses are millimeters. Bottom access panel is shown; top access panel is available.

NOMINAL LENGTH	L	LMHS INLET SIZE	W	H	LMHS INLET SIZE	AVAILABLE LENGTHS					
						12"	18"	24"	36"	48"	60"
12	12 1/4"	4-6	12"	8"	4-6	•	•	•	•	•	•
18	18 1/4"	7-8	12"	10"	7-8	•	•	•	•	•	•
24	24 1/4"	9-10	14"	12 1/2"	9-10	•	•	•	•	•	•
36	36 1/4"	12	16"	15"	12	•	•	•	•		
48	48 1/4"	14	20"	17 1/2"	14	•	•	•	•		
60	60 1/4"	16	24"	18"	16	•	•	•	•		
		22	38"	18"	22			•			

STANDARD FEATURES

- 20 gauge galvanized steel casing construction
- 1/2" thick dual density fiberglass insulation that meets NFPA 90A and UL 181 safety requirements
- Slip and drive connections (hardware not provided)

OPTIONAL FEATURES

- Liners: 1" dual density fiberglass, 1/2" or 1" cellular, Steriliner, 1/2" or 1" Sterilwall, 1/2" or 1" perforated doublewall
- Access Door: Single, bottom access door
- Access Door: Dual, top and bottom, access door*
- Access Door Fastening: Screws or cam locks*
- Hanger brackets*

* Not available with size 22.