

## ATNS SINGLE DUCT ATTENUATOR

## SUBMITTAL SHEET

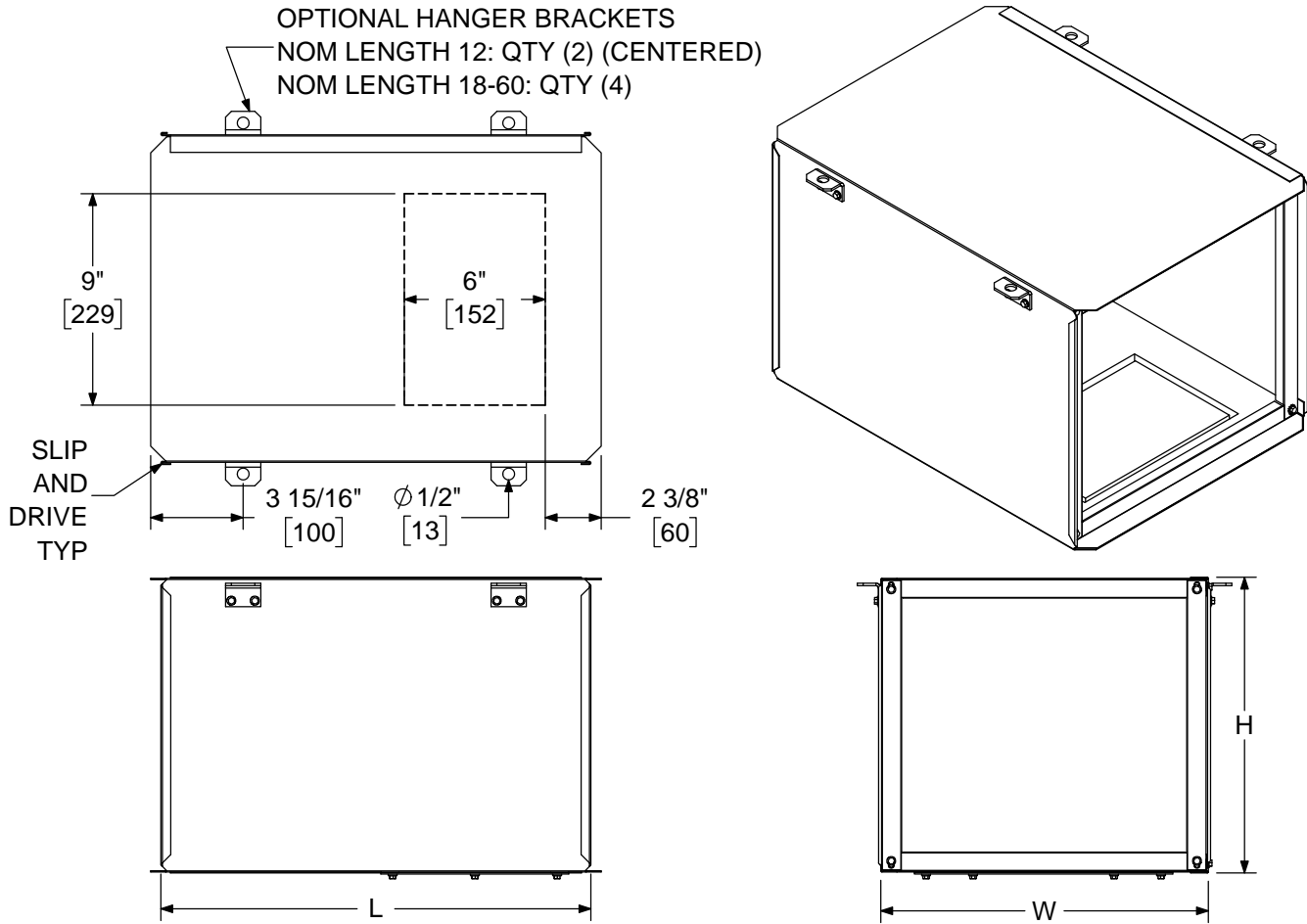

UNITS SHOWN ARE IN [MM]

NOM LENGTH	L
12	12-1/4 [311]
18	18-1/4 [464]
24	24-1/4 [616]
36	36-1/4 [921]
48	48-1/4 [1226]
60	60-1/4 [1530]

LMHS INLET SIZE	W	H
4-6	12 [305]	8 [203]
7-8	12 [305]	10 [254]
9-10	14 [356]	12-1/2 [318]
12	16 [406]	15 [381]
14	20 [508]	17-1/2 [445]
16	24 [610]	18 [457]
22	38 [965]	18 [457]

LMHS INLET SIZE	AVAILABLE LENGTHS					
	12	18	24	36	48	60
4-6	•	•	•	•	•	•
7-8	•	•	•	•	•	•
9-10	•	•	•	•	•	•
12	•	•	•	•		
14	•	•	•	•		
16	•	•	•	•		
22			•			

### STANDARD FEATURES:

- 20 GA Steel Construction
- 1/2" Thick dual Density Fiberglass Insulation
- Slip & Drive Connections (Hardware Not Provided)

### OPTIONAL FEATURES:

- Liners:
  - 1" dual density fiberglass
  - Steriliner
  - 1" Sterilwall
  - 1" Perforated Double Wall
  - 1" Cellular
- Access Door:
  - Single w/ Screws
  - Single w/ Cams\*
- Hanger Brackets\*
- 1/2" Dual Density Fiberglass
- 1/2" Sterilwall
- 1/2" Perforated Double Wall
- 1/2" Cellular
- Dual w/ Screws\*
- Dual w/ Cams\*

\*Not available with size 22