

5100 SERIES

LAMINAR FLOW AIR SUPPLY DEVICE WITH ACCESSORIES

SUBMITTAL SHEET

DIMENSIONS

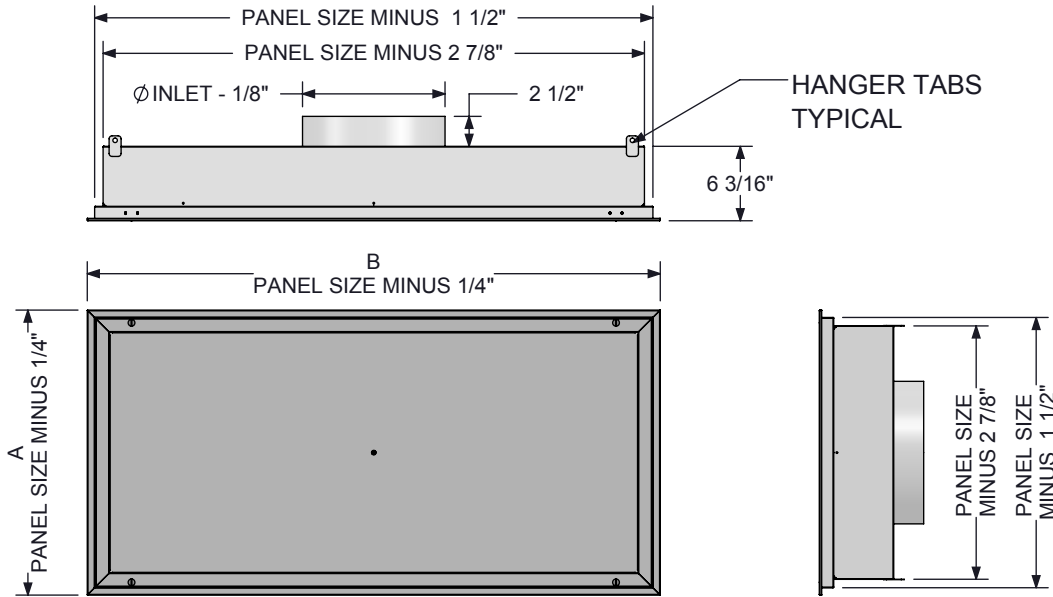

PANEL SIZE	A	B
12 X 24	11.75	23.75
12 X 48	11.75	47.75
12 X 60	11.75	59.75
12 X 72	11.75	71.75
24 X 24	23.75	23.75
24 X 36	23.75	35.75
24 X 48	23.75	47.75
24 X 60	23.75	59.75
24 X 72	23.75	71.75
36 X 48	35.75	47.75
36 X 60	35.75	59.75

GENERAL DESCRIPTION

- Model 5100 laminar flow diffuser generates a low velocity, evenly distributed, downward moving "piston" of conditioned air.
- Installed over the operating table in a hospital operating room, Model 5100 helps to protect the patient from contaminated air. The only appreciable amount of room air entrainment occurs at the boundaries of the moving air mass outside the confines of the operating table. As a result, the patient is effectively isolated from residual room air.
- Model 5100 is especially effective in cooling areas with heavy, localized, internal loads, as in a computer room. The column of air delivered by the 5100 cools the load source directly without generating high velocities in the occupied space.
- Trim disc within perforated deflector ring allows minor equalization adjustment and is accessible through the face.
- Perforated face is quickly removed by loosening 1/4 turn fasteners.
- Retainer cables prevent accidental dropping of perforated face after removal.
- Internal baffles distribute air evenly over perforated face.
- 13% free area perforated face has 3/32" diameter holes on 1/4" centers on 60° staggered pattern.
- Can be surface mounted or laid into conventional T-bar ceiling system.
- Compatible with 1" or 1 1/2" T-bar ceiling grids.

CONFIGURATION OPTIONS

Material

- Aluminum Face and Pan
- Aluminum Face and 304 Stainless Steel Pan
- 304 Stainless Steel Face and Pan*

Free Area

- 13% Free Area Perforated Face (Standard Capacity)
- 23% Free Area Perforated Face (Increased Capacity)
- 33% Free Area Perforated Face (Maximum Capacity)

Finish

- 01 - Mill Finish
- 44 - British White
- 4A - Anti-Microbial White
- 10 - Alumican

*316SS AVAILABLE ON REQUEST

INSULATION OPTIONS

- 1.5" Foil Faced External Insulation
- R6 Molded External Insulation
- Internal Fiber Free Insulation

ACCESSORY OPTIONS

- Butterfly Damper
- Welded Inlet
- LED Lights*
- Dual Chamber/ Equalization Baffle

*ONLY AVAILABLE FOR 24x24, 24x36 24x48 PANELS

Revision Date: 7/19/2019

Form: DS0305

Replaces: NEW

SHEET 1 OF 2

5100 SERIES

LAMINAR FLOW AIR SUPPLY DEVICE
WITH ACCESSORIES

JOB NAME _____
ENGINEER _____
CONTRACTOR _____
TAG _____

SUBMITTAL SHEET

QUARTER TURN DETAIL

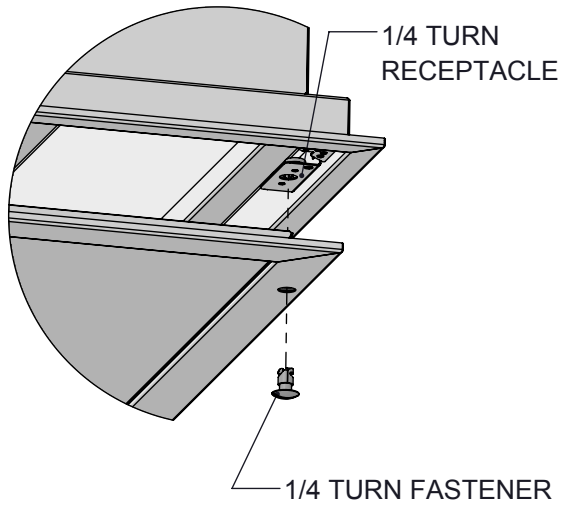

LED LIGHT DETAIL

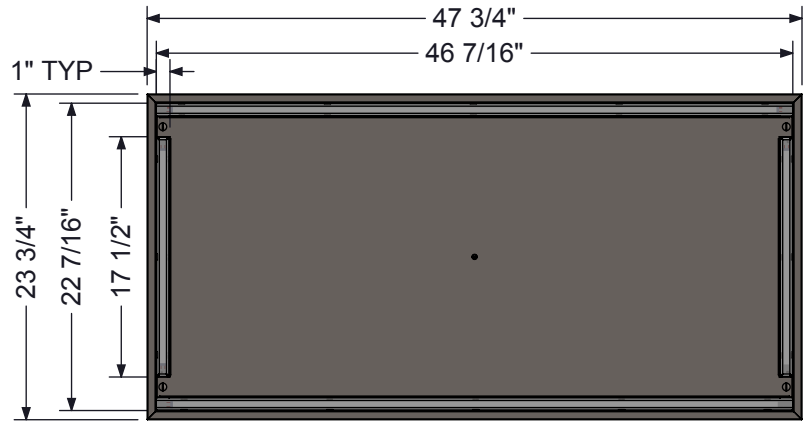

NOTE: 24 X 48 UNIT SHOWN

INSULATION DETAIL

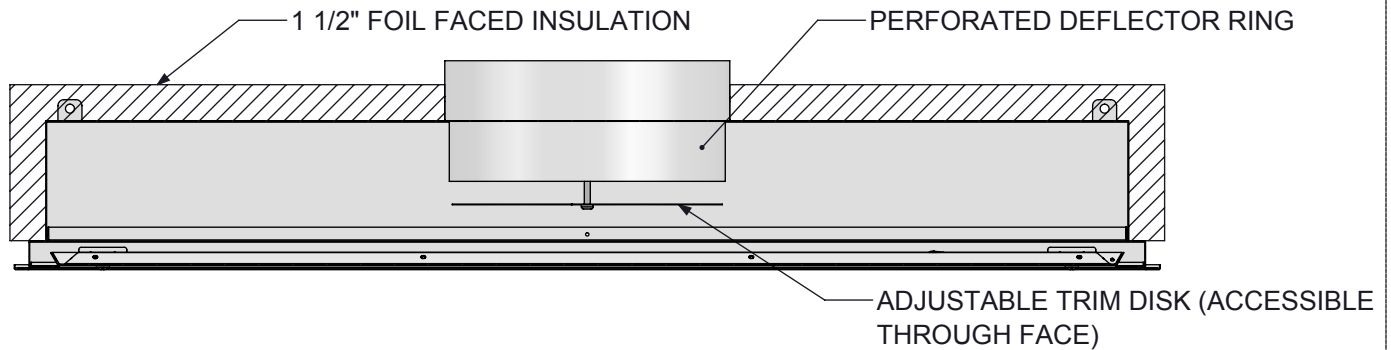

BUTTERFLY DAMPER DETAIL

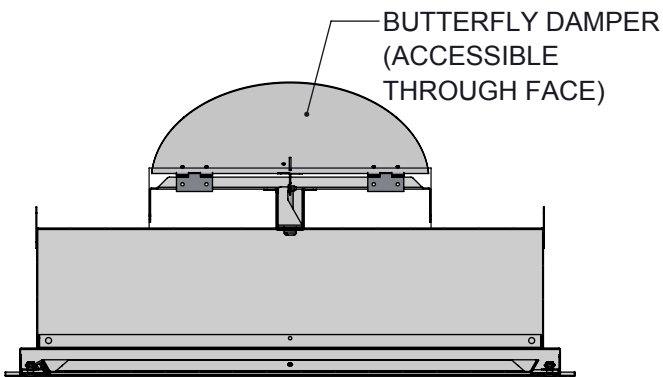

DUAL CHAMBER/ EQUALIZATION BAFFLE DETAIL

