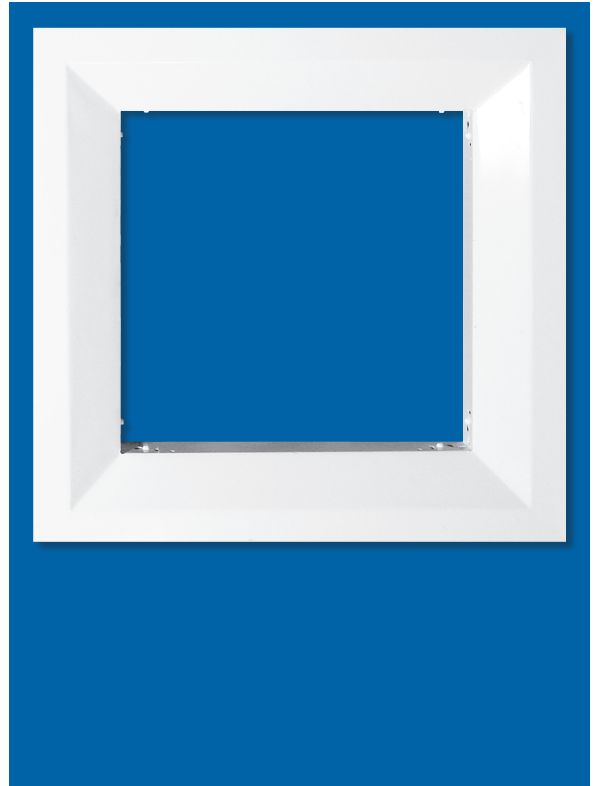

MODELS

- SHF - Steel frame
- 5SHF - Aluminum frame

FEATURES

- Allows for frame replacements on the SH/5SH and SHR/5SHR series diffusers
- Excellent choice for office layouts that have changing tenant requirements

**WEB SEARCH: SHF or 5SHF****MODELS**

- SHC - Steel core
- 5SHC - Aluminum core

FEATURES

- Allows for core replacements on the SH/5SH, SHV/5SHV, SHR/5SHR, SHPC/5SHPC, and SHPCR/5SHPCR series diffusers
- Excellent choice for office layouts that have changing tenant requirements

NOTE: For (5)SHV core, contact Krueger.

**WEB SEARCH: SHC or 5SHC**

SHF / SHC SERIES

Frames and Cores



DIMENSIONAL DATA

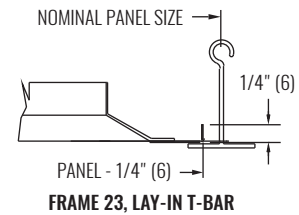
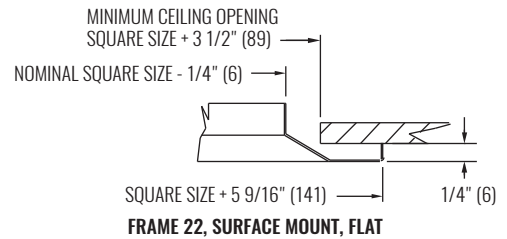
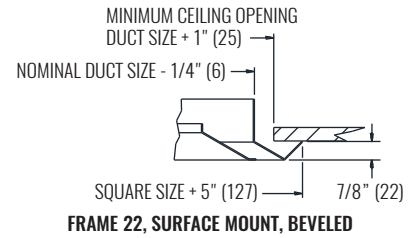
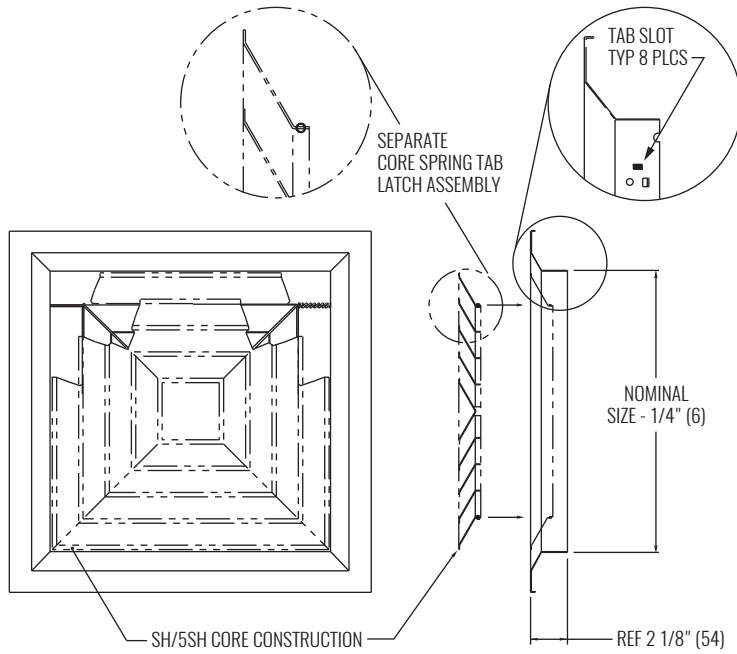

NOTES: Dimensions in parentheses are millimeters (mm). Illustrations shown are for a 24"x24" panel. Replacements are limited by existing core size.

DIMENSIONAL DATA (MODEL SHC)

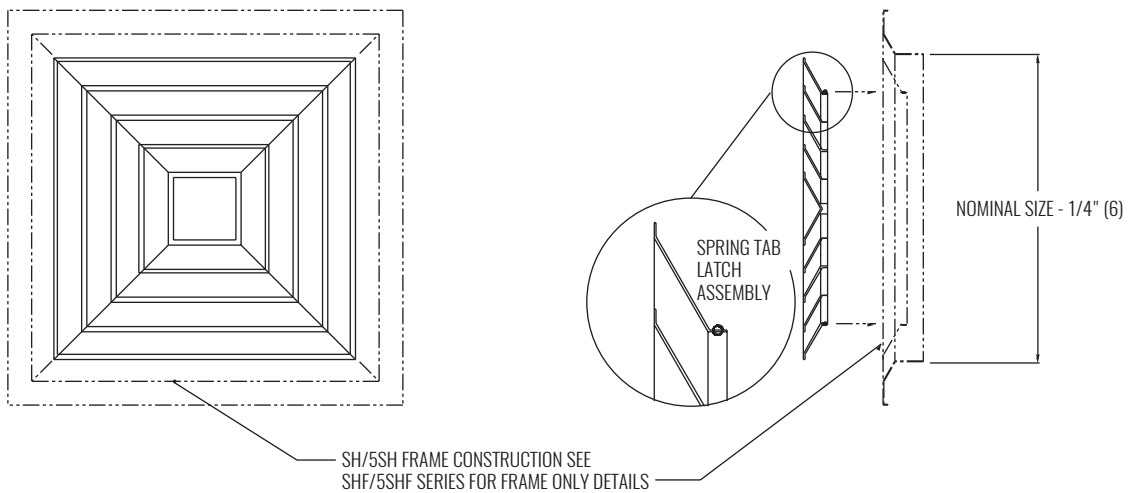

NOTES: Dimensions in parentheses are millimeters (mm). Replacements are limited by existing core size.